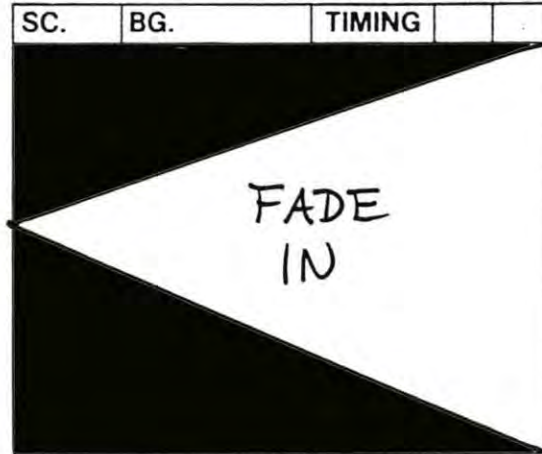

FILM ROMAN

THE SIMPSONS

TITLE _____ SHOW BABF 19 ACT I PAGE 1

SC.	BG.	TIMING
<p>"BEHIND THE LAUGHTER" BABF 19 ACT I STORYBOARD BY BOB MILLER</p>		

SC.	BG.	TIMING
 <p>FADE IN</p>		

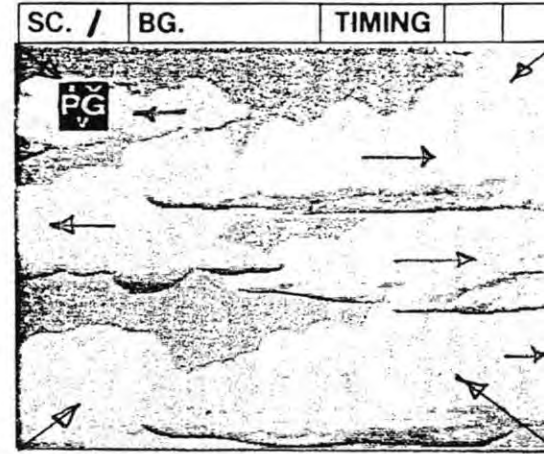
SC. /	BG.	TIMING
		

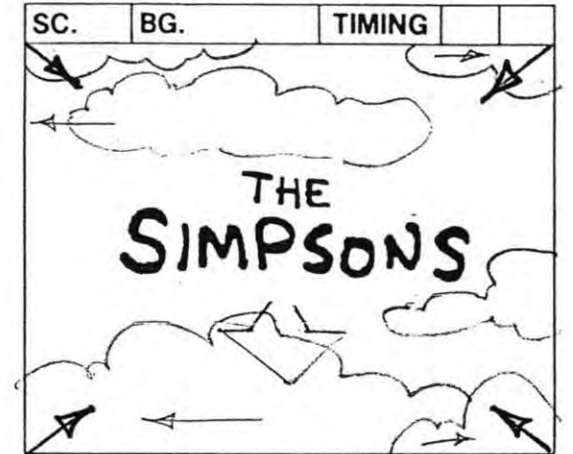
SC.	BG.	TIMING
<p>THE SIMPSONS</p> 		

ACTION		<p><u>OPENING SEQUENCE</u> FADE IN:</p>	<p>EXT. SKY - DAY The clouds part as in the normal show opening. TRUCK IN AS CLOUDS PART</p>
TRANS.			
DIAL			
TRANS.			
NOTES			

FILM ROMAN

THE SIMPSONS

TITLE _____

SHOW BABF19

ACT I

PAGE 2

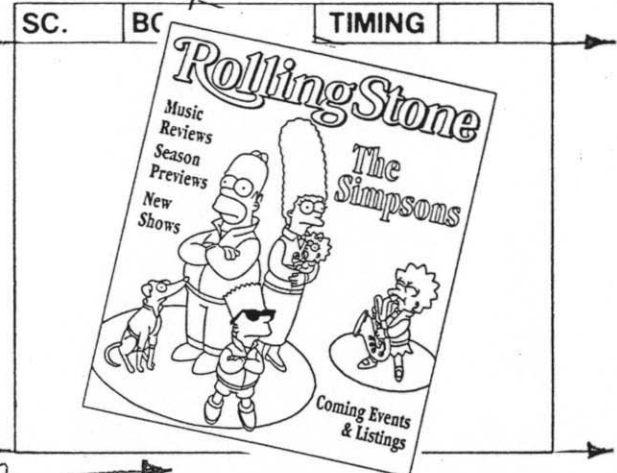
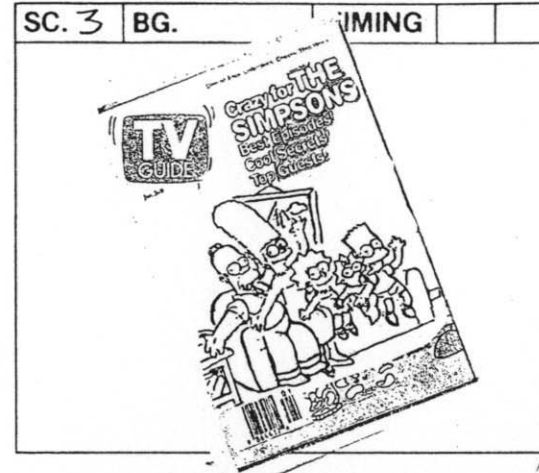
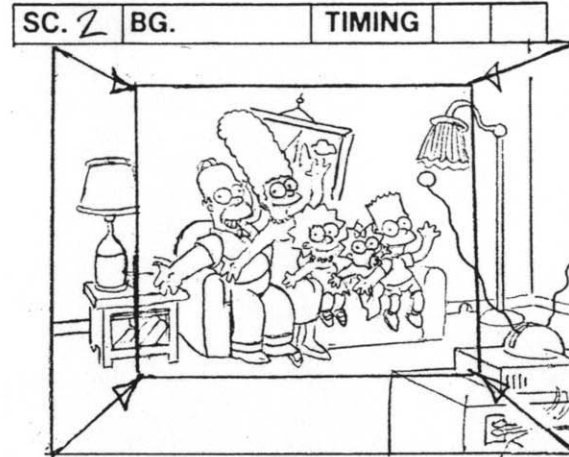
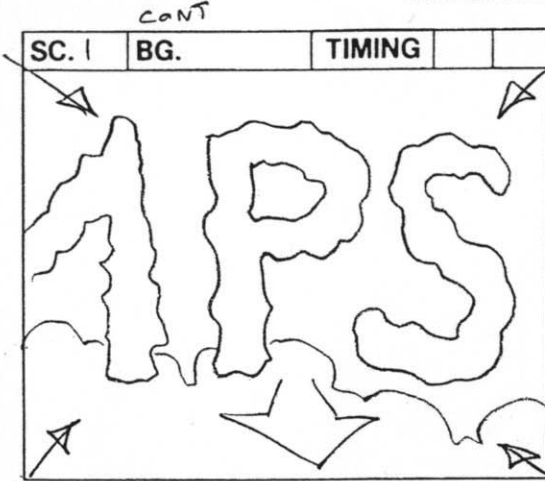

ACTION

CONTINUE TRUCK-IN.

We CUT TO a shot of the smiling SIMPSONS, sitting on the couch in a "Ta da" pose.

TRUCK-IN.

We see the Simpsons on a series of magazine covers (which float through frame): "TV Guide", "Rolling Stone",

PAN TV GUIDE COVER

Design by Jeff Warkley

TRANS.

DIAL

NARRATOR (V.O.)

They were the first family of American laughter...

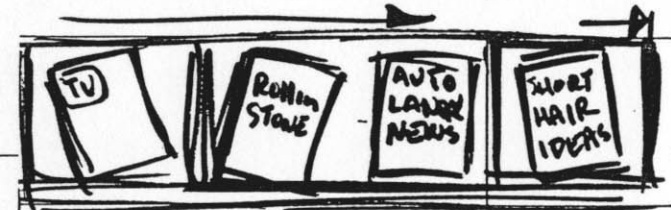

PAN →

TRANS.

NOTES

FILM ROMAN

THE SIMPSONS

3 CONT.

TITLE _____

SHOW BABE19

ACT I

PAGE 3

cont'd Pan

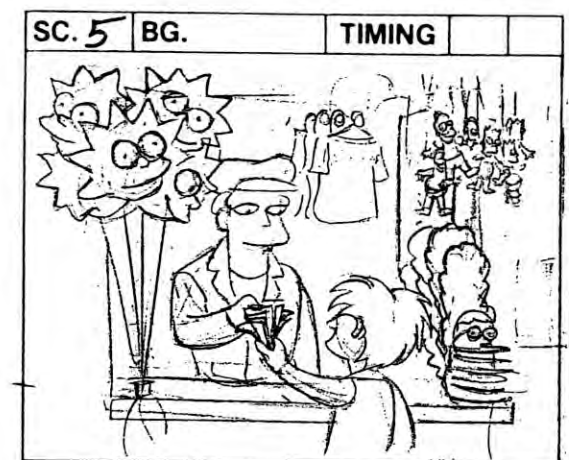
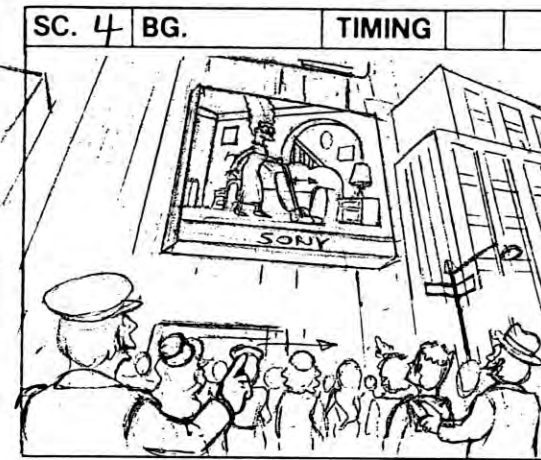
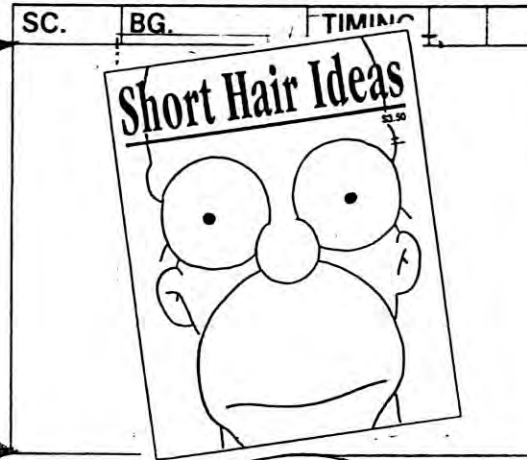

stop

ACTION	CONTINUE PAN - "Auto Laundry News",	STOP PAN and "Short Hair Ideas".	EXT. TIMES SQUARE - NIGHT A CROWD of people watches "The Simpsons" on the Jumbotron. (On the screen, we see a shot of Marge vacuuming.)	EXT. STREET CORNER A SIDEWALK VENDOR sells various "Simpsons" merchandise (T-shirts, balloons, hats, marionettes). A KID hands the vendor a wad of bills.
TRANS.	Design by Kevin Moore.	Design by Jeff Wockley	* Have shot of crowd laughing hysterically... A few people point up at the screen.	
DIAL			NARRATOR (V.O.) (CONT'D) ... surfing a tidal wave of hilarity...	
TRANS.				
NOTES				

FILM ROMAN

THE SIMPSONS

5 CONT.

TITLE _____

SHOW BABF19

ACT I

PAGE 4

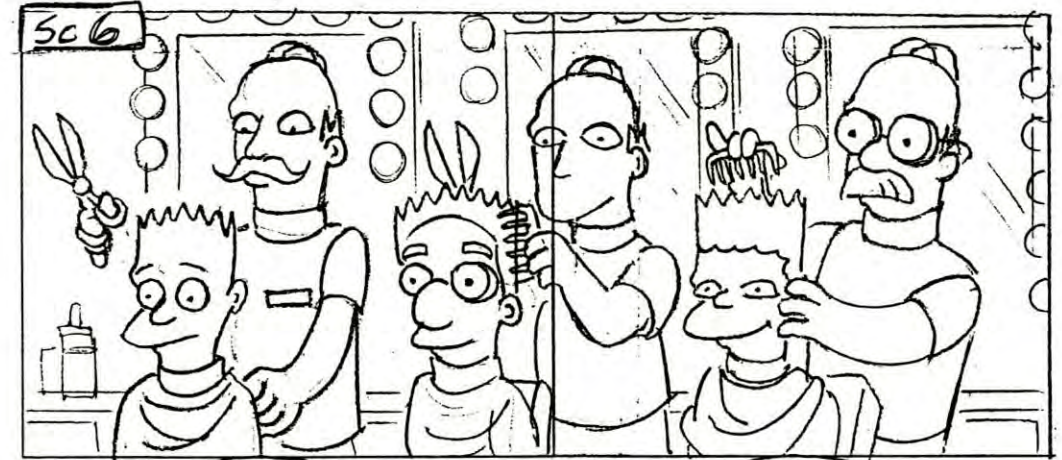
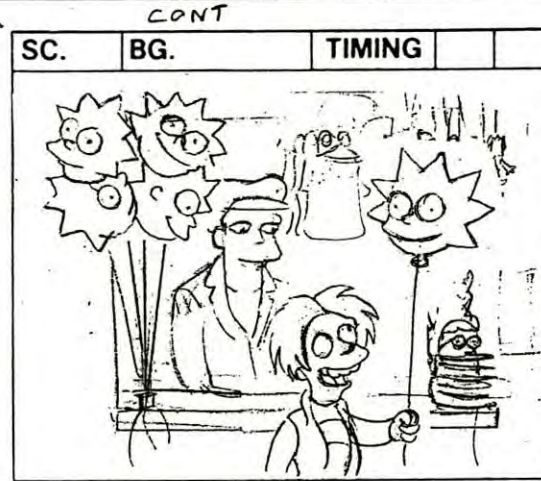
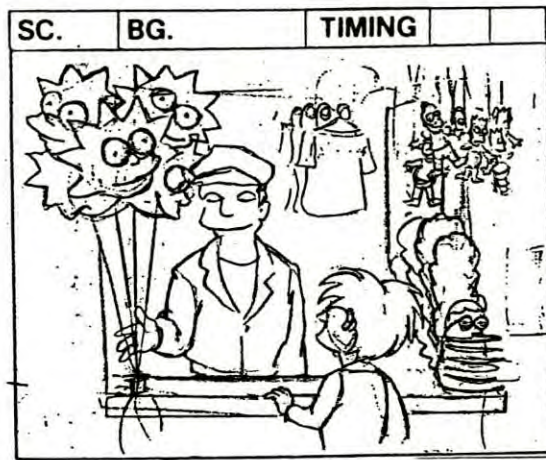

Stop ←

PAN

→ Start

ACTION

The vendor hands him a balloon.

THE KID TAKES THE BALLOON.

INT. BARBER SHOP

A ROW OF KIDS are receiving Bart-style haircuts from BARBERS with Homer-style hair.

PAN LEFT TO RIGHT. (* use generic kids)

TRANS.

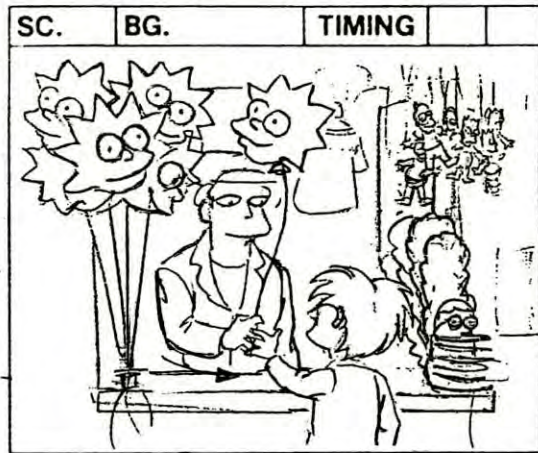

DIAL

NARRATOR (V.O.) (CONT'D)

... onto the sands of Superstar Bay.

TRANS.

NOTES

FILM ROMAN

THE SIMPSONS

TITLE _____

SHOW BABF19

ACT I

PAGE 5

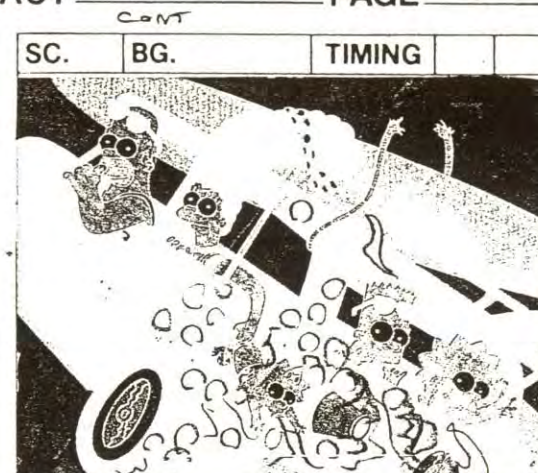
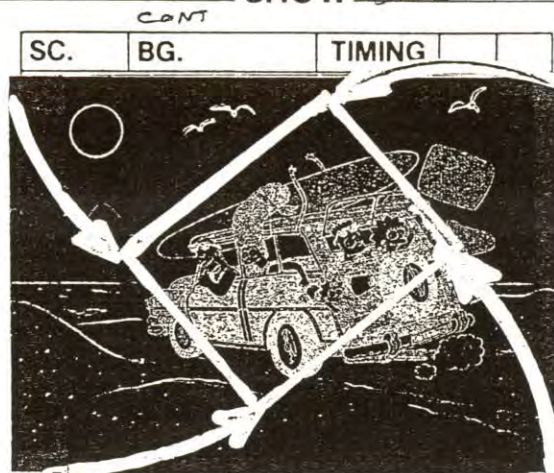
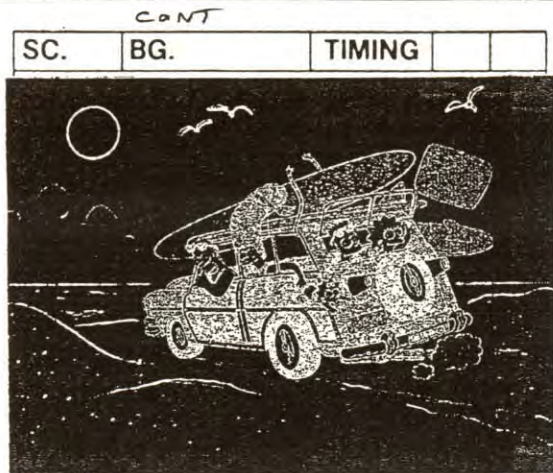
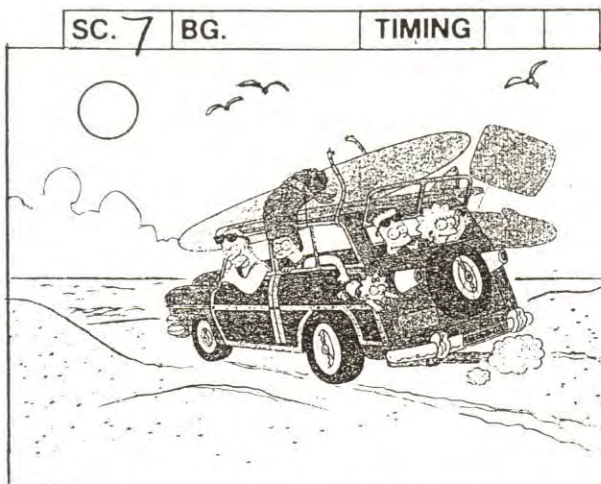

ACTION	We see a promotional photo of the smiling family at the beach in an old-style "woody" station wagon. We hear an OMINOUS PIANO STING,	and the picture slowly turns to a black and white negative.	(The camera ROTATES as it slowly PUSHES IN.)	FLAMES BURN PHOTO NEGATIVE STARTING AT BOTTOM. EMULSION BUBBLES.
TRANS.			(NOTE TO ANIMATORS: Throughout the show, we will use dissolves and <u>push-ins</u> for dramatic effect.)	
DIAL	NARRATOR (V.O.) But behind the chortles,	this funny fivesome was trapped in a private hell.		
TRANS.				
NOTES				

FILM ROMAN

THE SIMPSONS

TITLE _____

SHOW BABF19

ACT I

PAGE 6

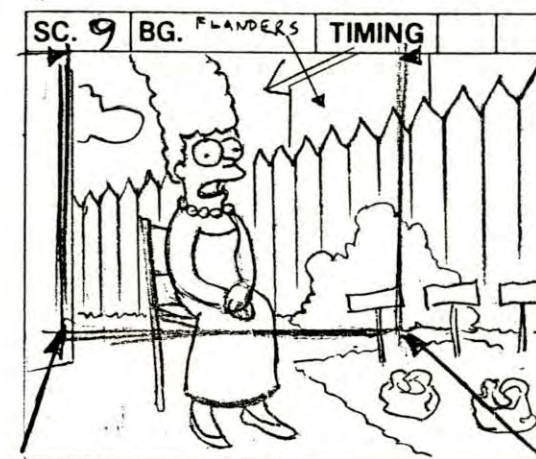
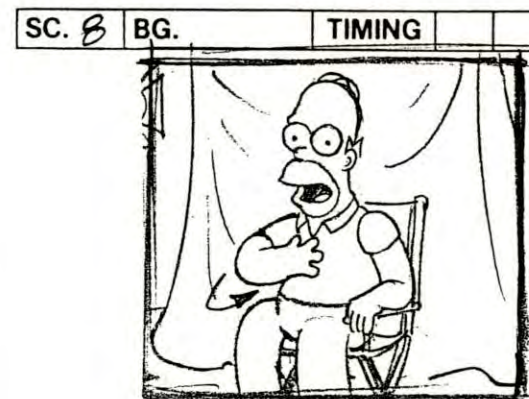
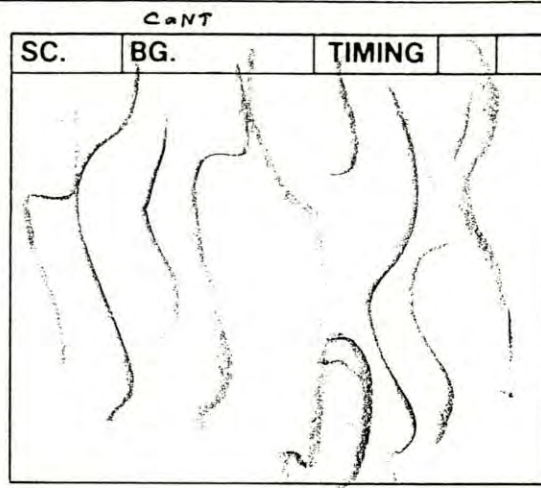
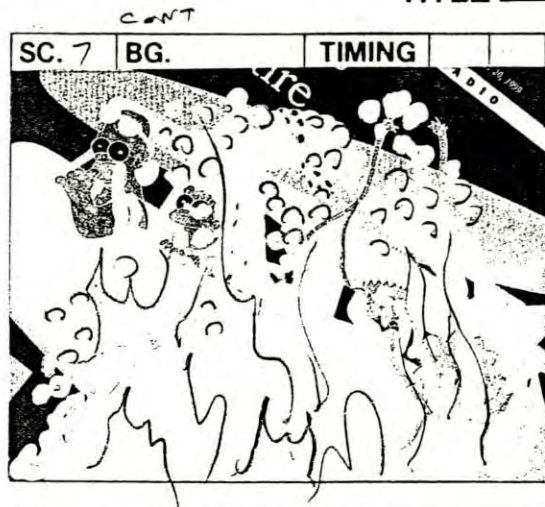

ACTION

The picture BURSTS into flames.	FLAMES CONSUME THE VIEW	We CUT TO Homer, sitting in a director's chair in front of a dark gray dropcloth. HOMER INTERVIEW	CUT TO Marge, sitting in the Simpsons' backyard by her garden. <i>TRUCK-IN closer</i> MARGE INTERVIEW
--	-------------------------	--	---

TRANS.

DIAL

		HOMER Everybody wanted a piece of us.	MARGE They told us what to wear, how to dress, which clothes we should put on...
--	--	--	---

TRANS.

NOTES

--	--	--	--

FILM ROMAN

THE SIMPSONS

TITLE _____

SHOW BABF19

ACT I

PAGE 7

SMALL FIELD PAN SETUP

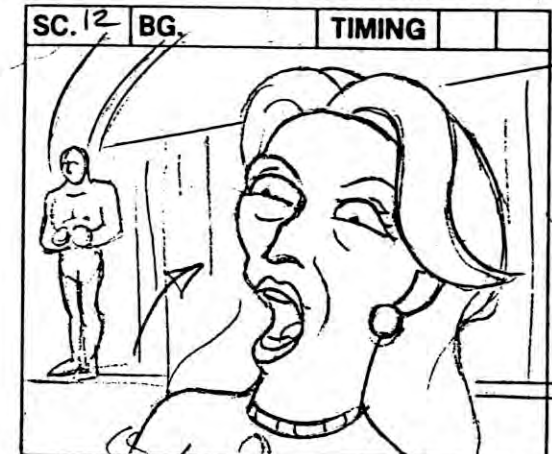
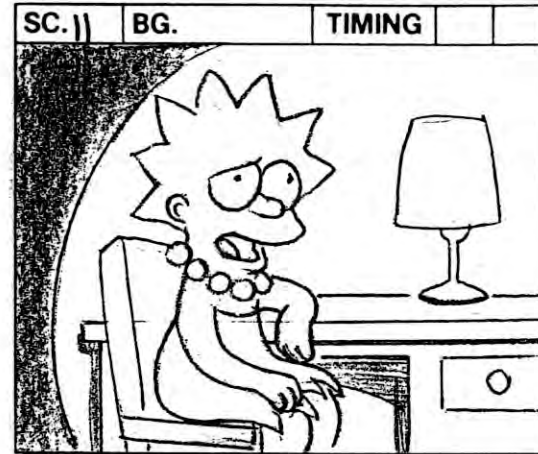
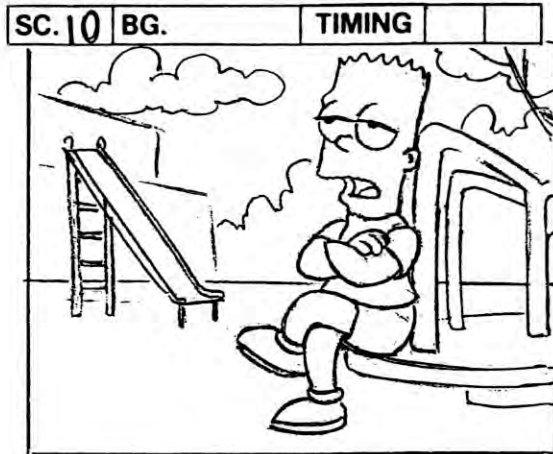

ACTION

CUT TO Bart, sitting on a playground merry-go-round.

BART INTERVIEW

CUT TO Lisa, sitting at her desk.

LISA INTERVIEW

INT. OSCAR STAGE.

CUT TO a CLOSE-UP of an angry MERYL STREEP SHE ANTICS TO SPIT.

TRANS.

DIAL

BART

The cops found me driving on the sidewalk.

LISA

I had no business hosting the Oscars. After the show, Meryl Streep spit on me.

TRANS.

NOTES

FILM ROMAN

THE SIMPSONS

TITLE _____

SHOW BABF19

ACT I

PAGE 8

CONT

SC. 12	BG.	TIMING		
--------	-----	--------	--	--

SC.	BG.	TIMING		
-----	-----	--------	--	--

SC.	BG.	TIMING		
-----	-----	--------	--	--

SC.	BG.	TIMING		
-----	-----	--------	--	--

ACTION
TRANS.
DIAL
TRANS.
NOTES

START
STOP

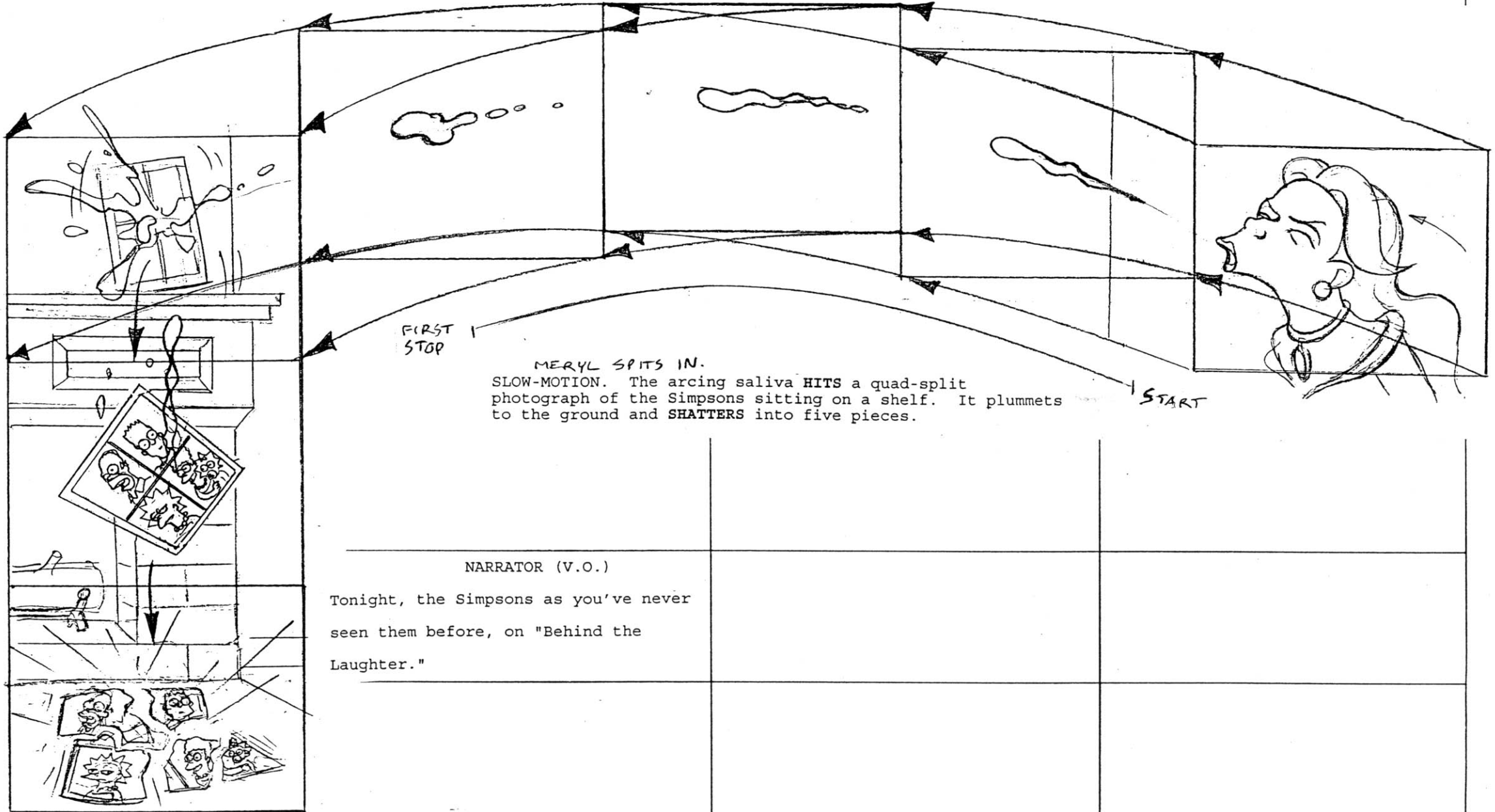

FIRST STOP

MERYL SPITS IN.
SLOW-MOTION. The arcing saliva HITS a quad-split photograph of the Simpsons sitting on a shelf. It plummets to the ground and SHATTERS into five pieces.

START

NARRATOR (V.O.)

Tonight, the Simpsons as you've never seen them before, on "Behind the Laughter."

FILM ROMAN

THE SIMPSONS

TITLE _____ SHOW BABF19 ACT I PAGE 9

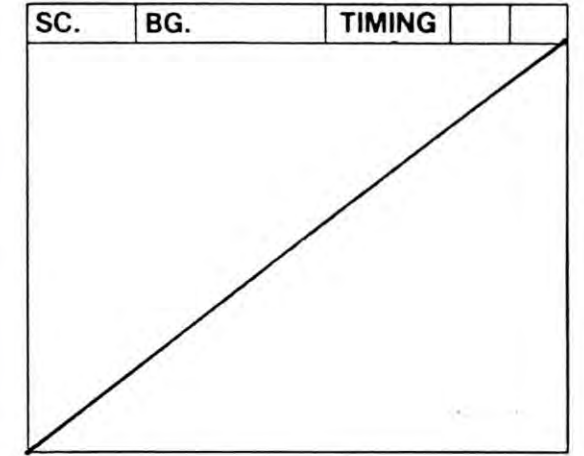
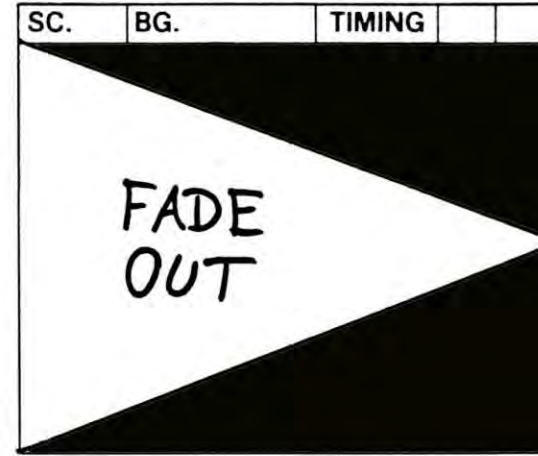
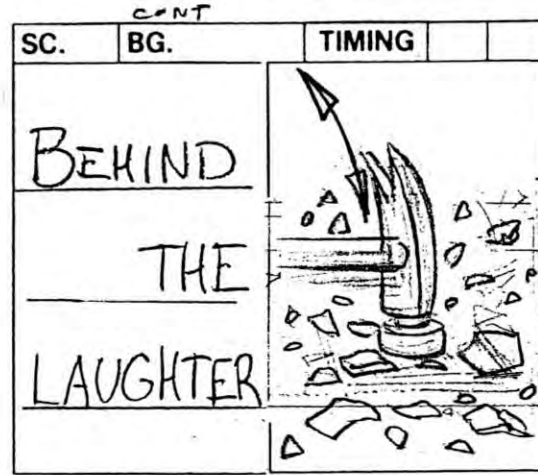
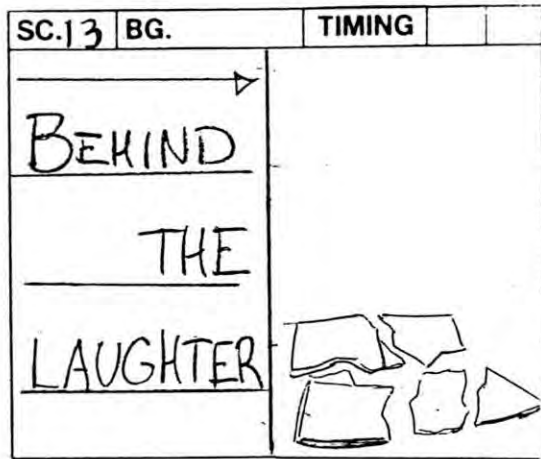

ACTION	<p>A "Behind the Music"-style logo flies in and fills the left half of the screen.</p>	<p>On the right half of the screen, a hammer repeatedly POUNDS the already-shattered picture.</p> <p><i>ANIMATE LETTERS *pounds 3-4 times)</i></p>	<p><u>END OF OPENING SEQUENCE</u></p>
TRANS.			
DIAL			
TRANS.			
NOTES			

FILM ROMAN

THE SIMPSONS

TITLE _____

SHOW BABF19

ACT I

PAGE 16

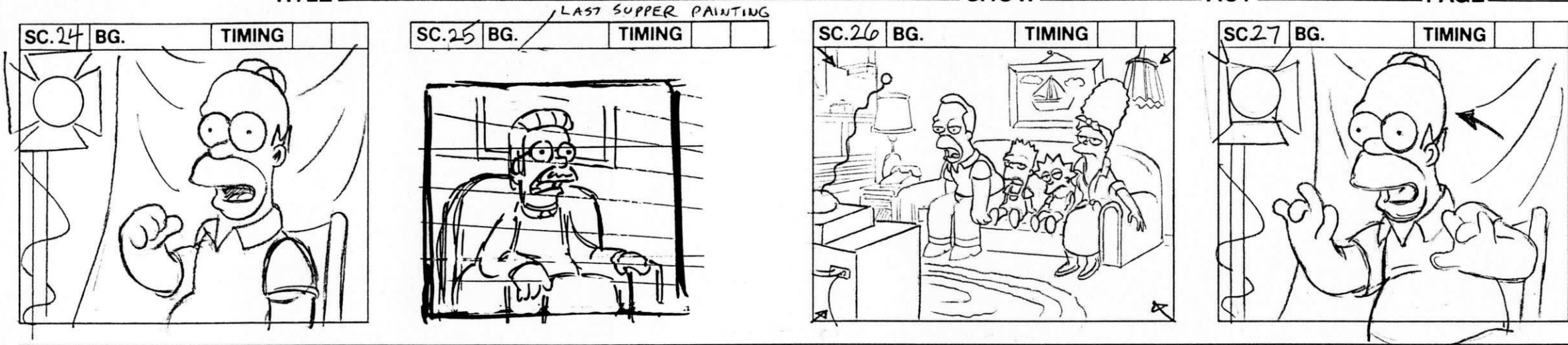

ACTION	<p>INT. STUDIO.</p> <p>HOMER INTERVIEW</p>	<p>DISSOLVE TO FLANDERS, sitting in his rumpus room. A SUPER APPEARS: "NED FLANDERS - Neighbor".</p>	<p>INT. SIMPSONS T.V. ROOM.</p> <p>PUSH IN on a still photo of the (younger) Simpsons, gazing moronically at the TV.</p>	<p>INT. STUDIO</p> <p>HOMER INTERVIEW</p>
TRANS.				
DIAL	<p>HOMER</p> <p>Then we figured out we could park them in front of the TV. That's how I was raised, and I turned out TV.</p>	<p>FLANDERS</p> <p>I'd see 'em sittin' on that couch all day long...</p>	<p>FLANDERS (V.O.)</p> <p>... just starin' at that Hollywood hogwash.</p>	<p>HOMER</p> <p>Our favorite show was "Hollywood Hogwash." But we also loved "The Dreck Squad"...</p>
TRANS.				
NOTES				

FILM ROMAN

THE SIMPSONS

TITLE _____

SHOW BABF19

ACT I

PAGE 17

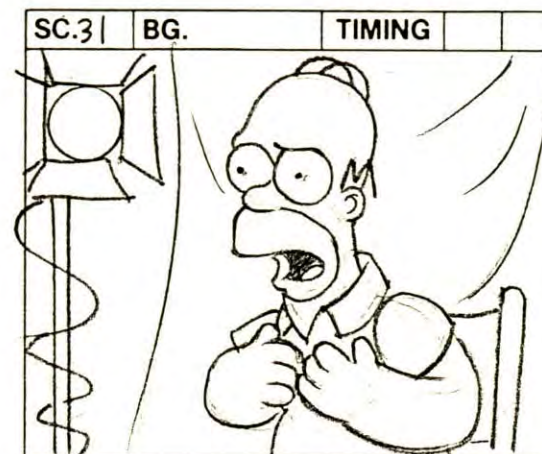
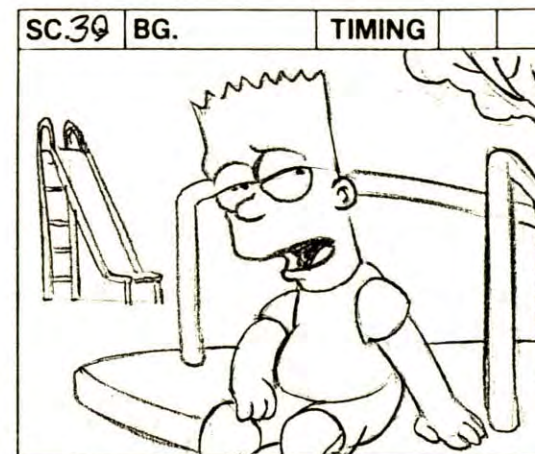
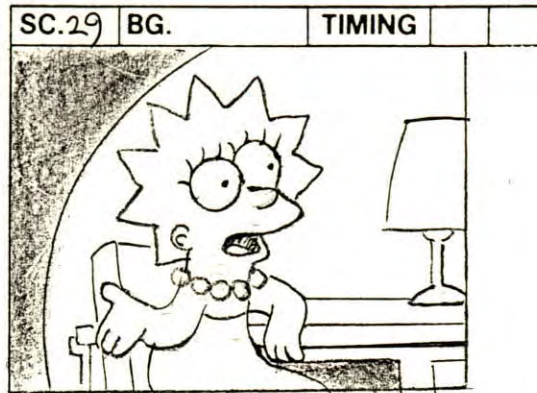
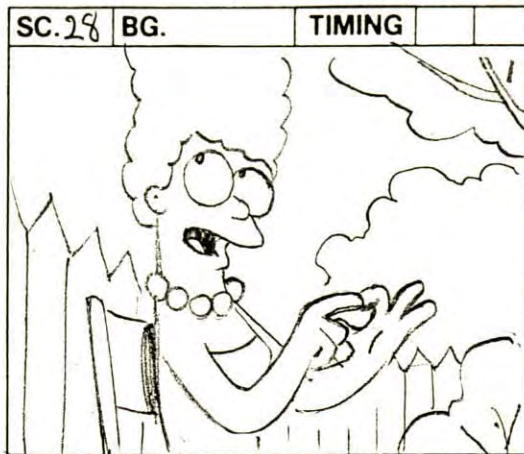

ACTION

EXT. SIMPSONS BACK YARD - DAY

INT. LISA'S ROOM

EXT. PLAYGROUND - DAY

INT. STUDIO

MARGE INTERVIEW

LISA INTERVIEW

BART INTERVIEW

HOMER INTERVIEW

TRANS.



DIAL

MARGE
(FONDLY, ENUMERATING ON FINGERS) "The Malarkeys," "Dumbin' It Down"...

LISA
"Sheriff Lowbrow"...

BART
"Home Improvement"...

HOMER
(DISSATISFIED) But we never saw people like us on TV.

TRANS.

NOTES

FILM ROMAN

THE SIMPSONS

TITLE _____

SHOW BABF19

ACT I

PAGE 18

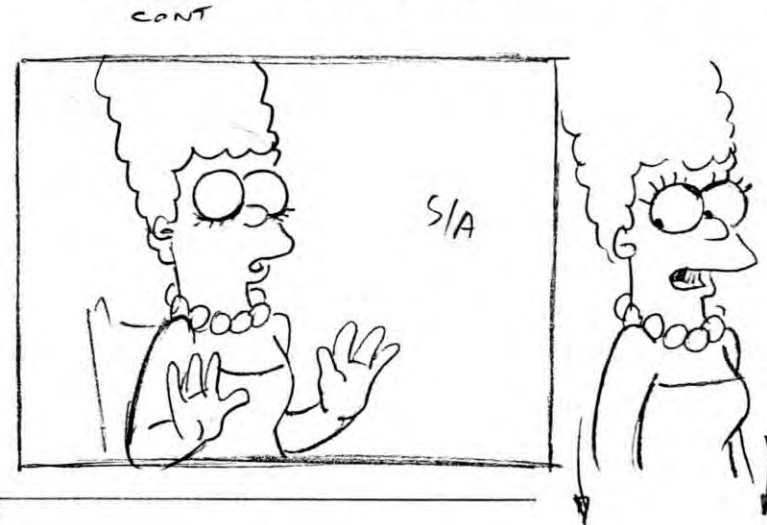
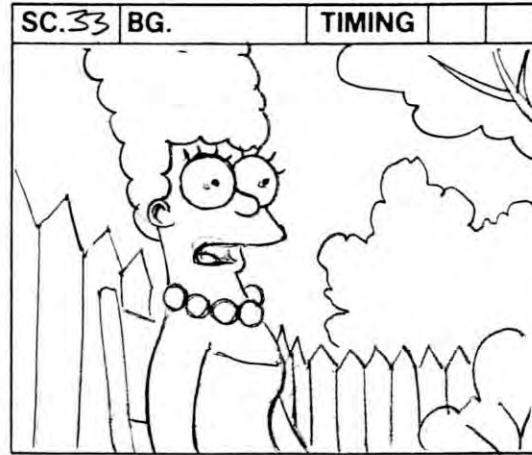
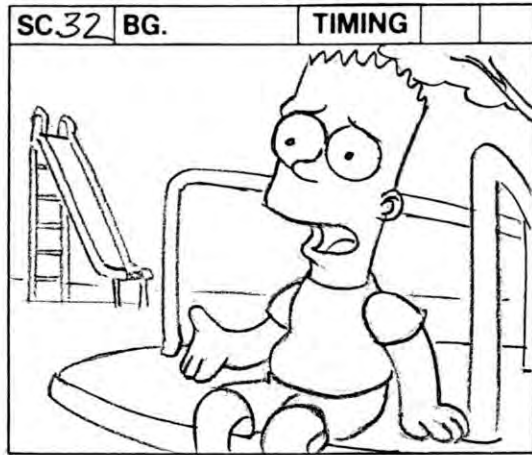

ACTION	EXT. PLAYGROUND - DAY BART INTERVIEW	EXT. BACK YARD - DAY MARGE INTERVIEW	
TRANS.			
DIAL	BART TV families were always hugging and tackling issues.	MARGE Homer kept saying he could do a more realistic family show.	Finally, I said, "So, do it! Either (BLEEP) or get off the pot."
TRANS.			
NOTES			

FILM ROMAN

THE SIMPSONS

TITLE _____

SHOW BABF19

ACT I

PAGE 19

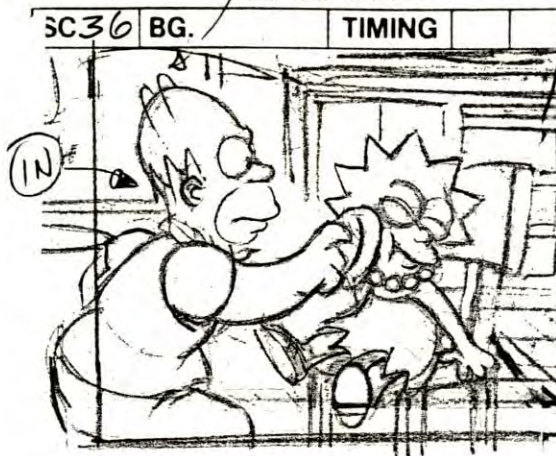
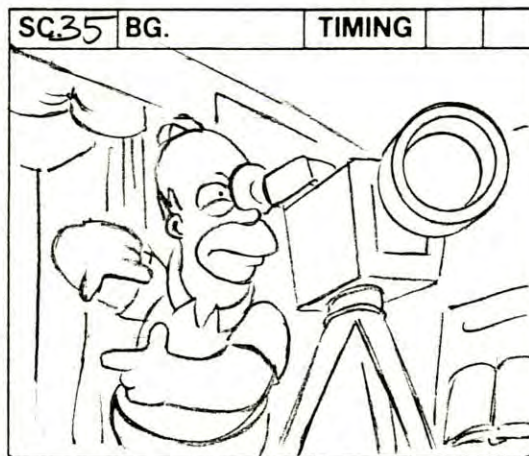
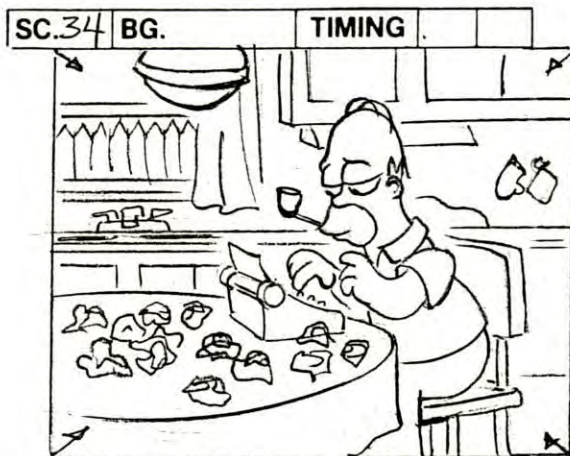

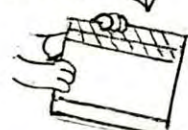
ACTION	<p>DRIFT IN TO HOMER.</p> <p>We DISSOLVE between STILLs of Homer typing a script (at the kitchen table, smoking a pipe),</p>	<p>peering through a video camera,</p>	<p>and applying make-up to Lisa.</p>	<p>INT. FOYER.</p>  <p>HOMER LIFTS CLAPPER TO CAMERA, HOLDS IT, SNAPS IT SHUT.</p>
TRANS.				<p>We see VIDEO FOOTAGE of Homer holding a clapper that reads, "My Funny Family".</p> <p>SUPER: "Early 'Simpsons' Test".</p> <p>OPTIONAL PRODUCTION NOTE: CAMERA ANGLE CAN BE TILTED</p>
DIAL	<p>NARRATOR (V.O.)</p> <p>And (BLEEP) he did.</p>	<p>NARRATOR (V.O.)</p> <p>Using his home as the studio, and his family as the cast, this penniless Peckinpah shot a crude five-minute video.</p>		<p>HOMER</p> <p>"My Funny Family," take one. (CLAPS BOARDS)</p>
TRANS.				<p>* Homer throws clapper down and runs (O.S.)</p>
NOTES				

FILM ROMAN

THE SIMPSONS

TITLE _____

SHOW BABF19

ACT I

PAGE 20

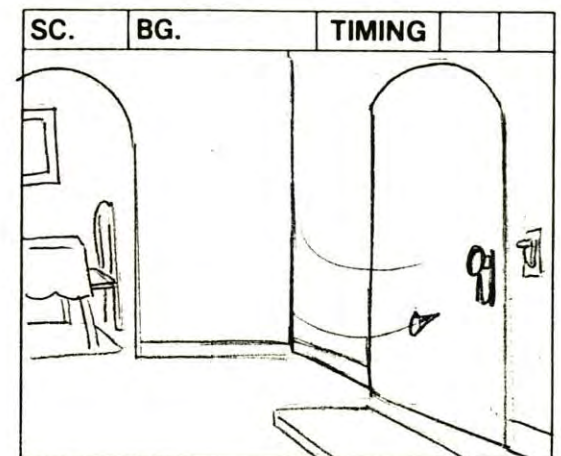
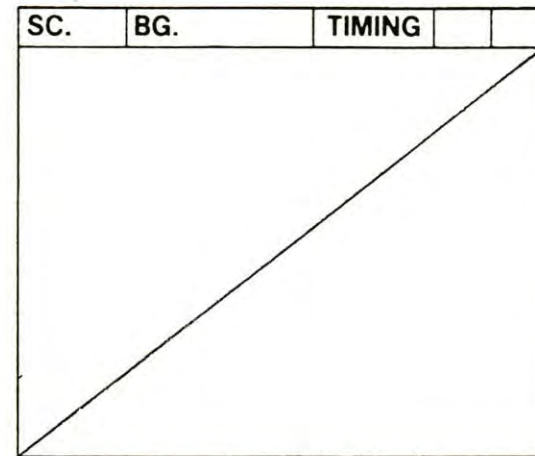
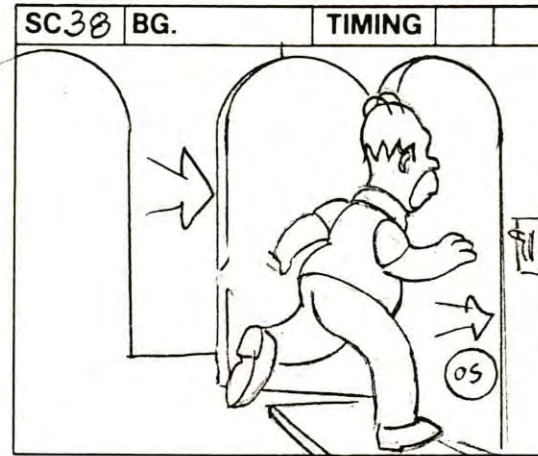
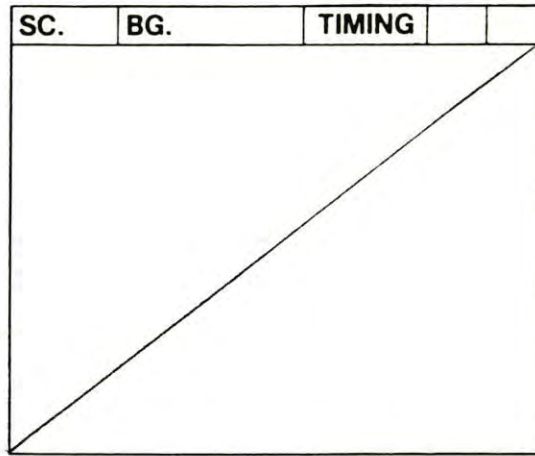

ACTION

Homer exits the front door,

A BEAT,
door closes.

TRANS.

DIAL

TRANS.

NOTES

FILM ROMAN

THE SIMPSONS

TITLE _____

SHOW BABF19

ACT I
38 CONT.

PAGE 21

SC.	BG.	TIMING	SC.	BG.	TIMING	SC.	BG.	TIMING

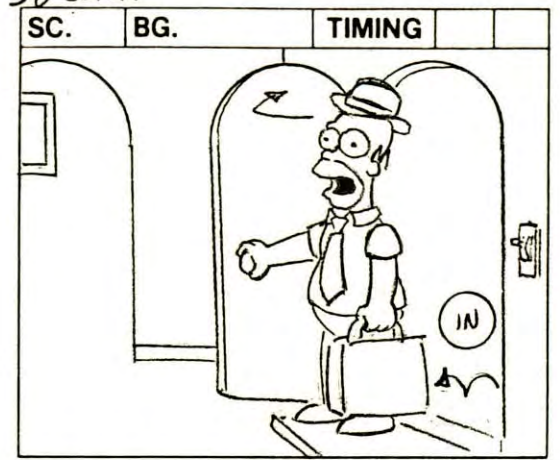

ACTION

HOMER
quickly re-enters carrying
a briefcase and wearing a hat.

TRANS.

DIAL

HOMER
Honey, I'm home! The boss is coming to
dinner and I need a clean shirt.

TRANS.

NOTES

FILM ROMAN

THE SIMPSONS

38 CONT,

TITLE _____

SHOW BABFI9

ACT I
CONT

PAGE 22

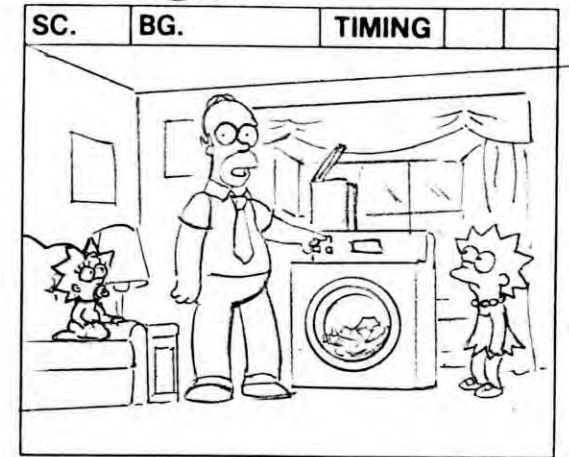
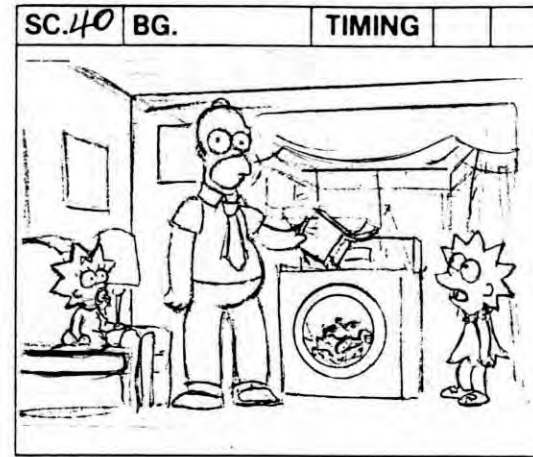
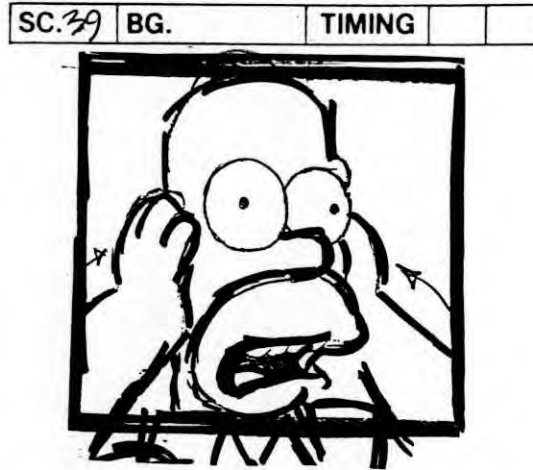
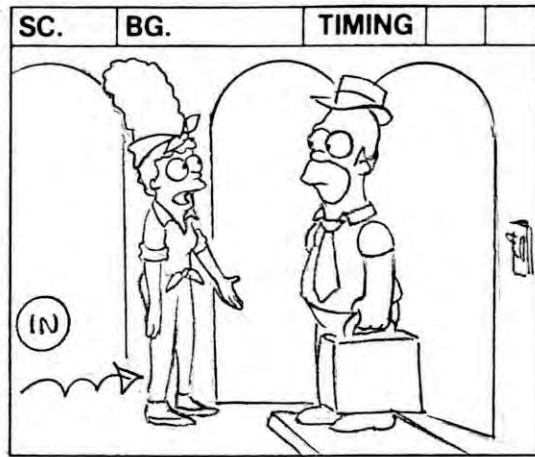

ACTION	MARGE STEPS INTO FRAME.	We CUT TO an EXTREME CLOSE-UP of Homer.	We CUT WIDE again. Homer pours a full box of laundry detergent into the washing machine, which is in the living room for some reason.
TRANS.			HOMER Not now. I'm busy turning on this washing machine.
DIAL	MARGE I haven't done the laundry yet.	HOMER Mamma mia! Now I'll have to do it.	LISA Dad, that's too much deterge--
TRANS.			
NOTES			

FILM ROMAN

THE SIMPSONS

40 CONT.

TITLE _____

SHOW BABF 19

ACT I

PAGE 22-A

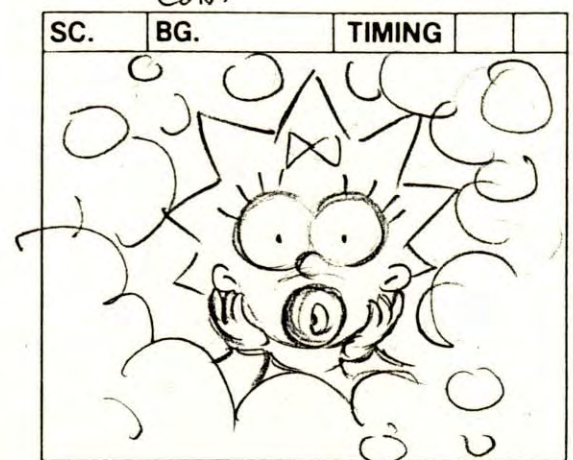
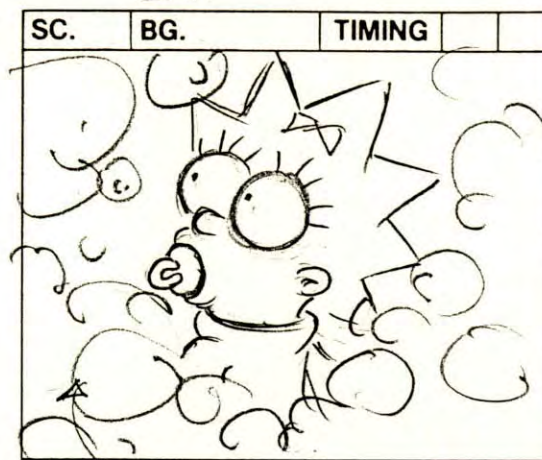
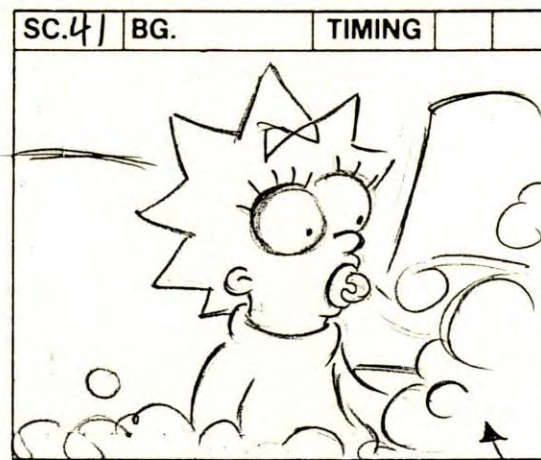
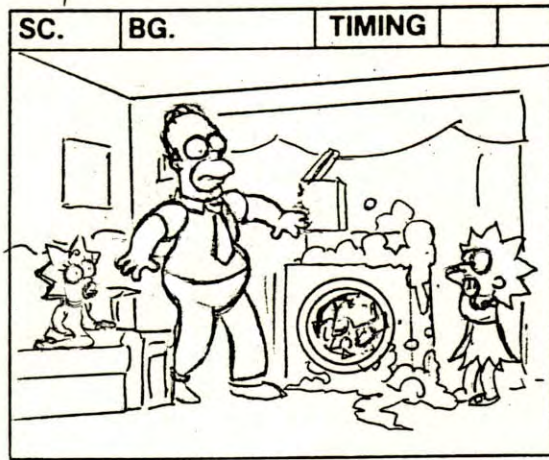

ACTION

Homer turns the washer on.
Immediately, soap suds begin billowing out of the machine.

Close on Maggie.
Bubbles push into sc.

Maggie turns to left
The bubbles starts filling up the screen.

Maggie turns to
Camera

TRANS.

DIAL

TRANS.

NOTES

FILM ROMAN

THE SIMPSONS

41 CONT.

TITLE _____

SHOW BABF19

ACT I

CONT

PAGE 23

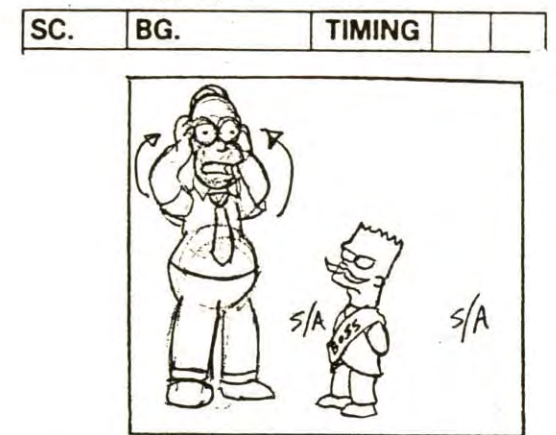
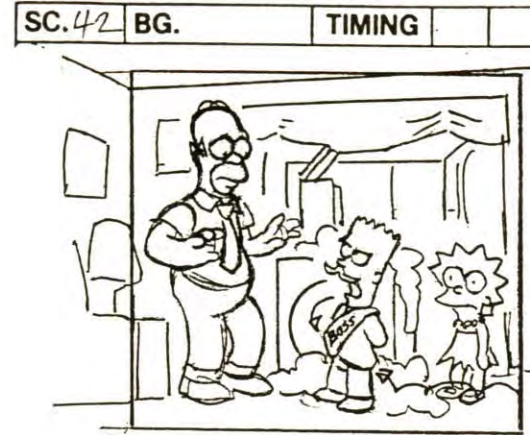
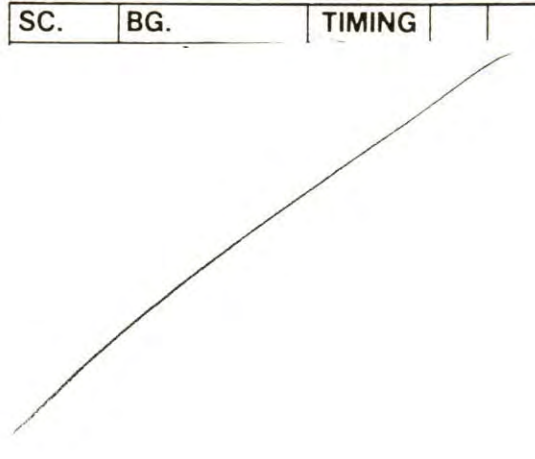
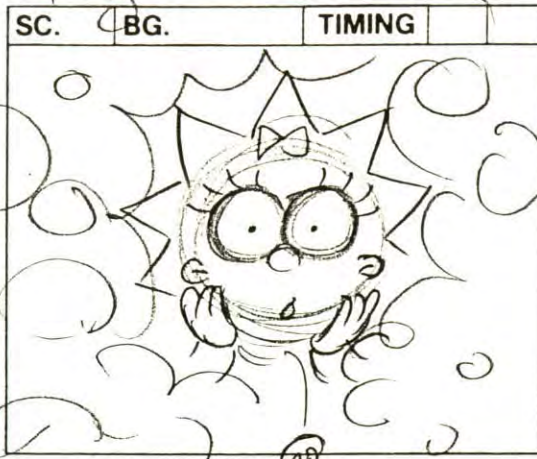

ACTION

05
Maggie drops the pacifier

TRANS.

DIAL

TRANS.

NOTES

Bart enters, wearing a suit, a fake mustache, and a sash that says "BOSS".

Homer turns to camera and does a big "Oh, no!" take.



BART
Simp-son!!! Where's my dinner?!

HOMER
Mamma mia!

FILM ROMAN

THE SIMPSONS

TITLE _____

SHOW BABF19

ACT I

PAGE 24

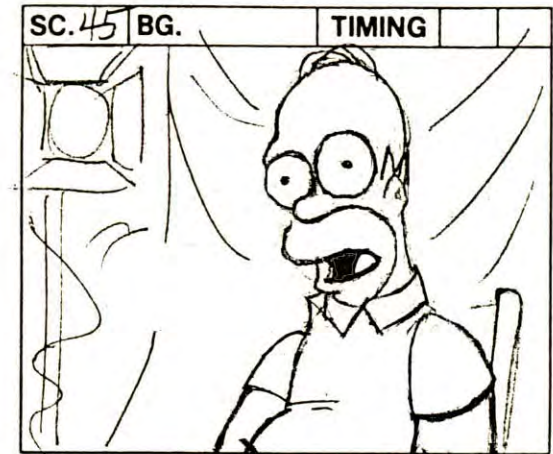
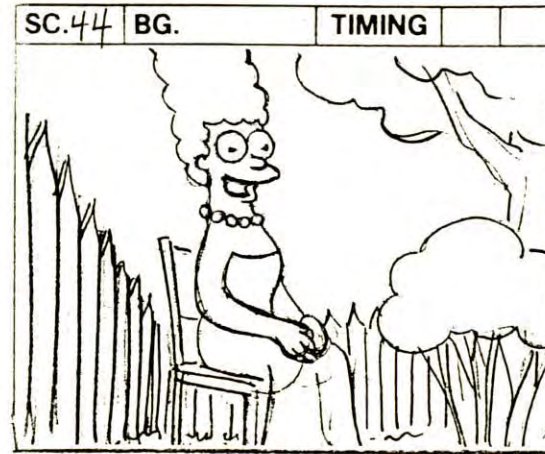
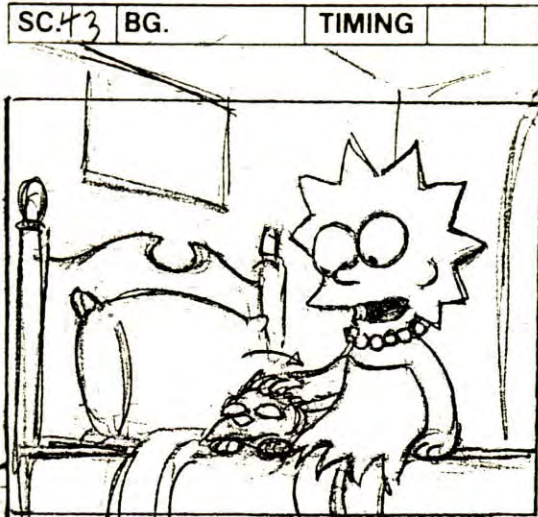
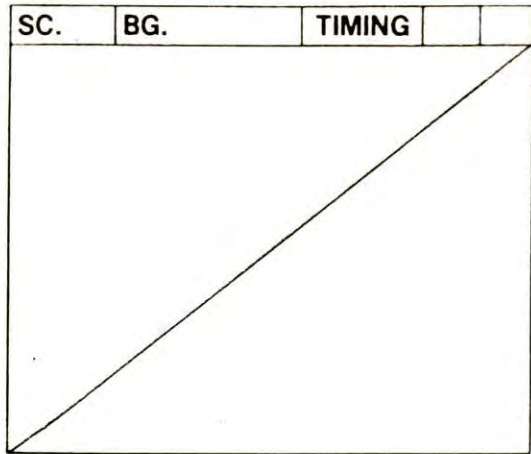

ACTION

LISA INTERVIEW

She's now sitting on her bed petting Snowball II.

EXT. BACK YARD-- DAY

MARGE INTERVIEW

INT. STUDIO.

HOMER INTERVIEW

TRANS.

OVERALL, I THINK WE SHOULD DO VERY SMALL ACTING IN THESE INTERVIEWS.

LISA LOOKS DOWN AT CAT, THEN UP.

DIAL

MARK K.

LISA

It was amazing how fast Dad betrayed his vision of a realistic show.

MARGE

Okay, the material was a little corny, but Homer and I had real chemistry onscreen.

HOMER

Every day I thought about firing Marge. You know, just to shake things up.

TRANS.

NOTES

FILM ROMAN

THE SIMPSONS

TITLE _____

SHOW BABF19

ACT I

PAGE 25

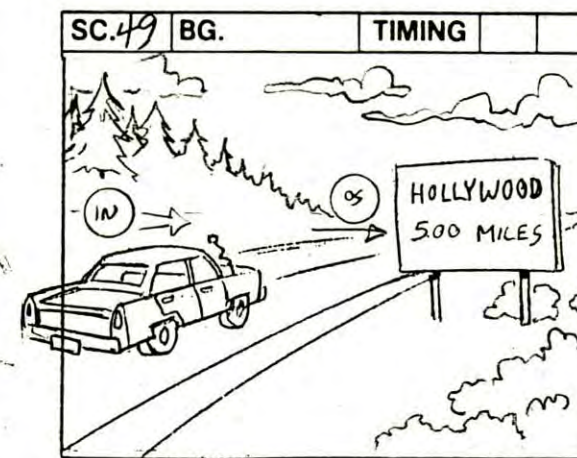
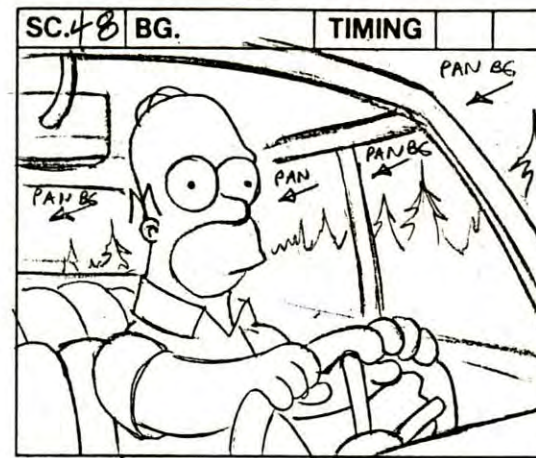
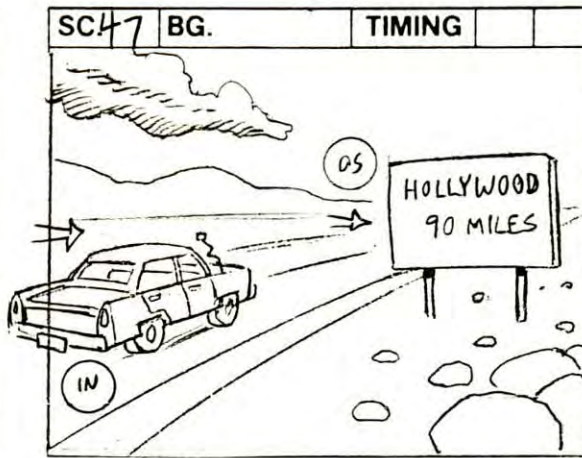
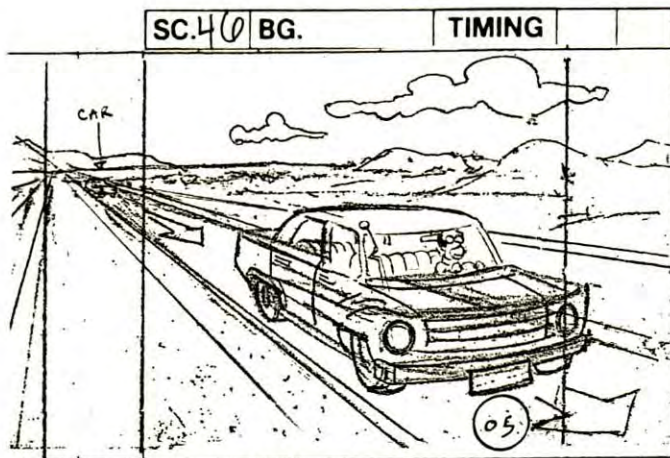

ACTION	EXT. ROAD - DAY. ADJUST RIGHT WITH CAR (HOMER IS DRIVING). CAR DRIVES TOWARD CAMERA RIGHT IN PERSPECTIVE. CAR EXITS FRAME RIGHT.	DISSOLVE TO	INT. CAR. PAN FOREST BG. RIGHT TO LEFT.	Homer driving past another sign that reads, "Hollywood - 500 miles". CAR DRIVES THRU FRAME IN PERSPECTIVE.
TRANS.				
DIAL	NARRATOR (V.O.) Homer didn't fire Marge, but he did shake things up. Show business things.			
TRANS.				
NOTES				

FILM ROMAN

THE SIMPSONS

TITLE _____

SHOW BABF19

ACT I
CONT

PAGE 26

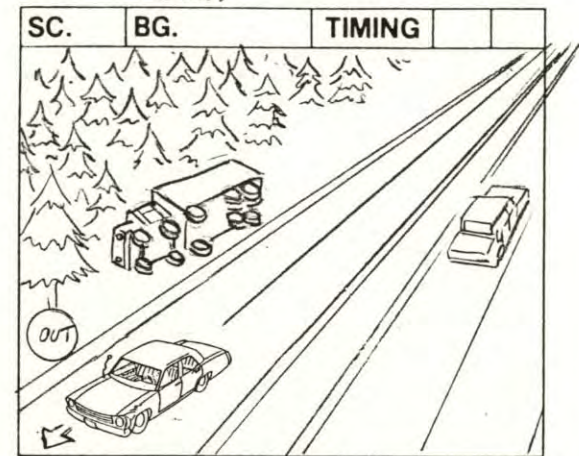
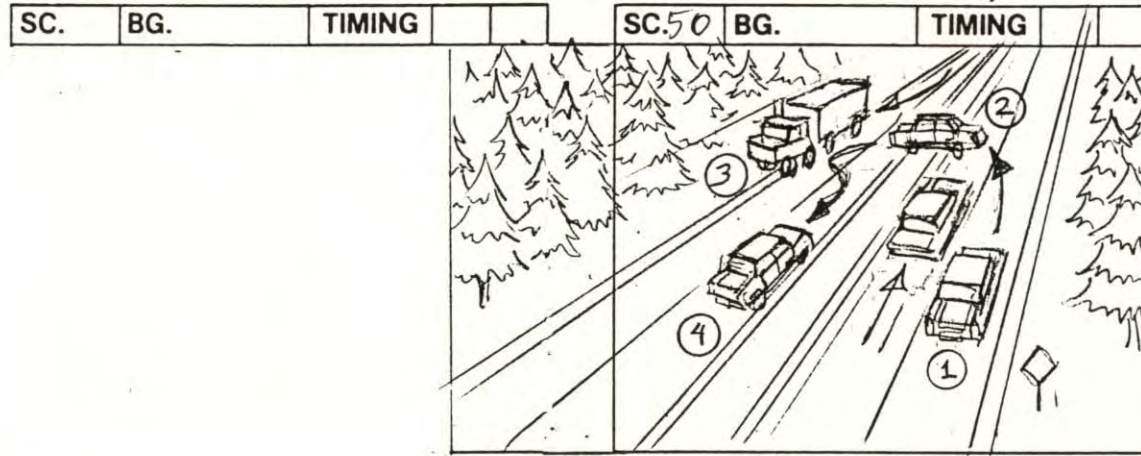
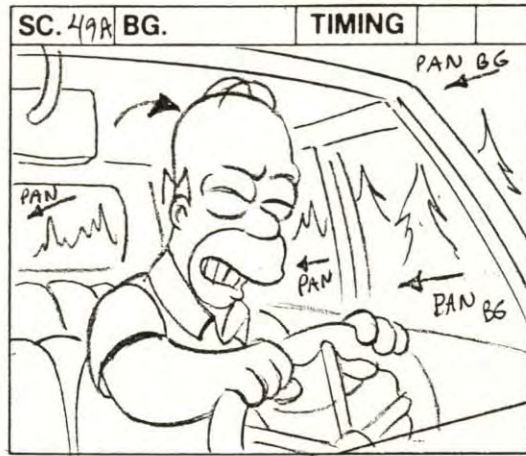

ACTION

He reacts, frustrated,

and pulls a RECKLESS U-TURN over the median.

TRUCK JACKKNIFES AS HOMER DRIVES O.S.

TRANS.

- ① HE TURNS IN FRONT OF CAR.
- ② ADJUST LEFT AS HE CROSSES MEDIAN
- ③ TRUCK SWERVES OUT OF HOMER'S WAY.
- ④ HOMER'S CAR TRAVELS TOWARD CAMERA LEFT IN PERSPECTIVE.

DIAL

TRANS.

NOTES

FILM ROMAN

THE SIMPSONS

TITLE _____

SHOW BABFIA

ACT I

PAGE 27

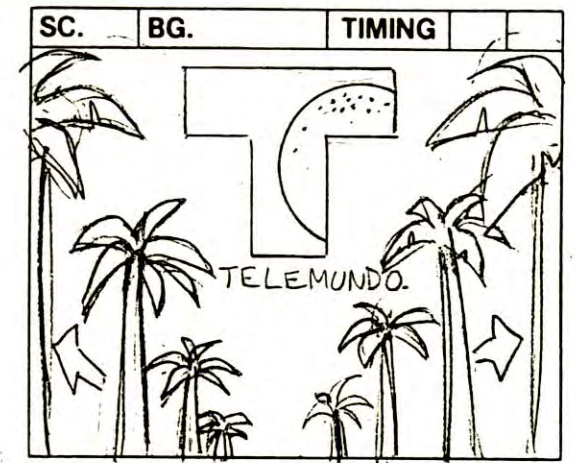
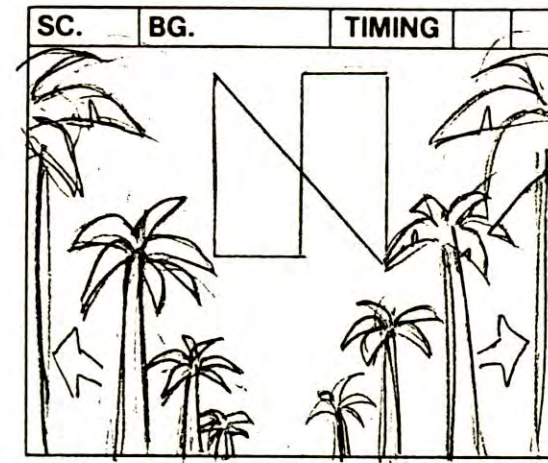
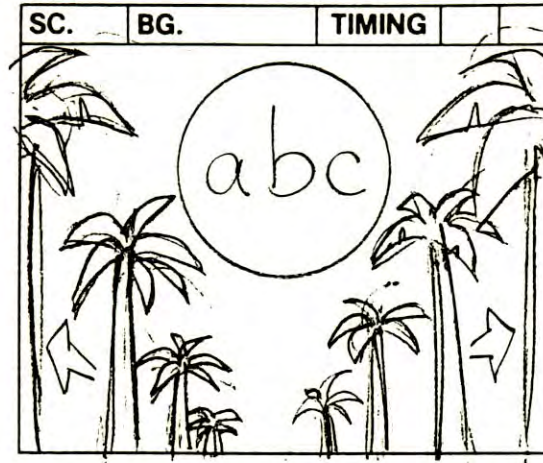
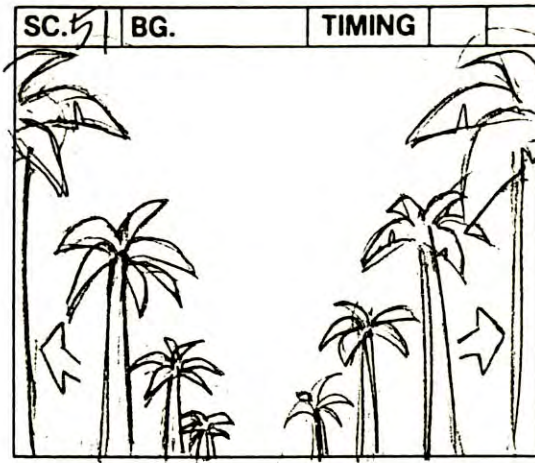

ACTION	<p>ANIMATE STYLIZED PALM TREES TOWARD CAMERA IN PERSPECTIVE.</p>	<p>The logos of ABC, NBC, and Telemundo sail past some stylized palm trees.</p>		
TRANS.				
DIAL		<p>NARRATOR (V.O.)</p> <p>He tried to show his demo tape to the major networks...</p>		
TRANS.				
NOTES				

FILM ROMAN

THE SIMPSONS

TITLE _____ SHOW BABF19 ACT I PAGE 28

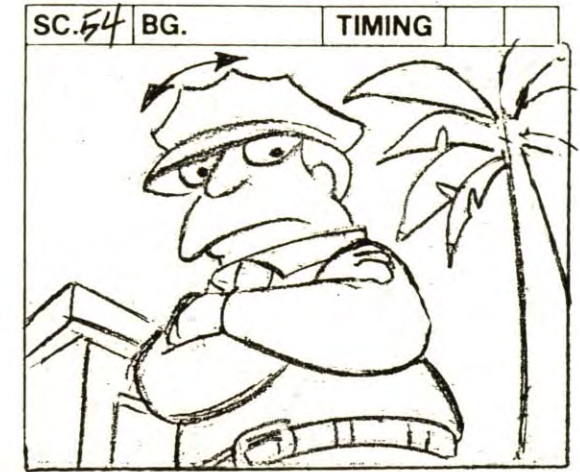
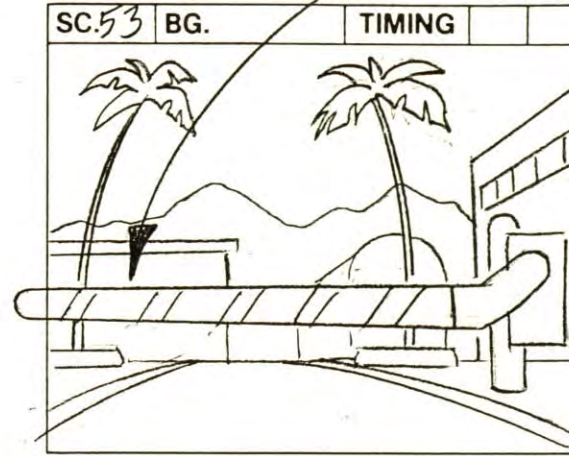
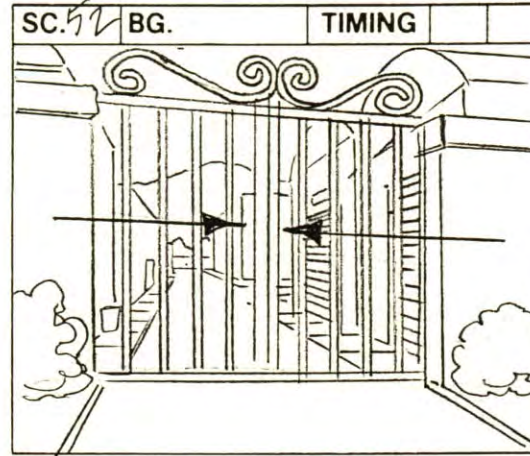
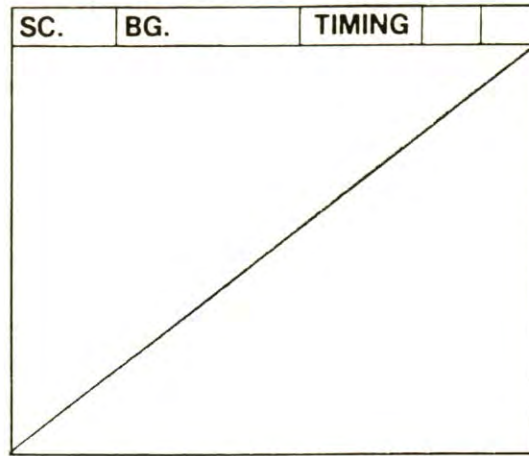

ACTION		<p>EXT. STUDIO - DAY.</p> <p>QUICK SHOTS of an ironwork entry gate CLANGING shut;</p>	<p>EXT. STUDIO - DAY.</p> <p>a guard-gate barrier arm coming down with a CLANG;</p>	<p>EXT. STUDIO - DAY.</p> <p>and a glowering STUDIO GUARD shaking his head "no" with CLANGING SOUNDS, for some reason.</p>
TRANS.				
DIAL		<p>NARRATOR (V.O.)</p> <p>... but couldn't get past the guards.</p>		
TRANS.				
NOTES				

FILM ROMAN

THE SIMPSONS

TITLE _____

SHOW BABY 19

ACT I

PAGE 29

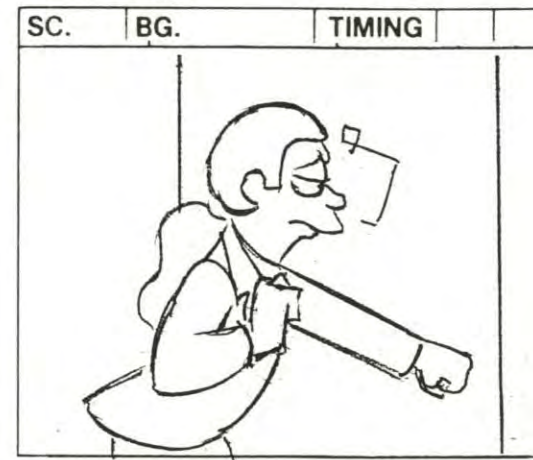
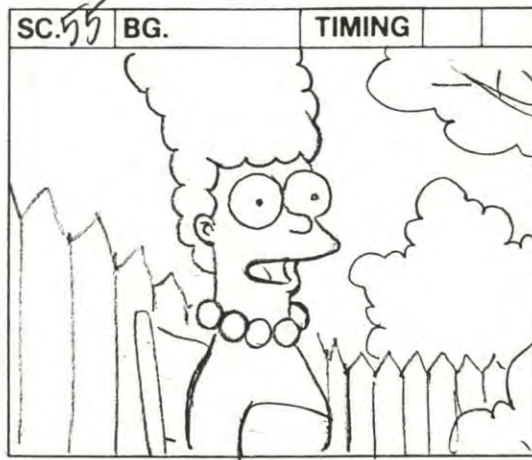

ACTION

EXT. BACK YARD - DAY.
MARGE INTERVIEW

CUT TO a FLAMBOYANT MAN opening a door marked "Fox Broadcasting" (in SLOW MOTION).

BRIGHT LIGHT WITHIN ROOM BEYOND DOOR.

TRANS.

DIAL

MARGE
Fortunately, I had a network connection. The man who cut my hair was also President of Fox.

TRANS.

NOTES

FILM ROMAN

THE SIMPSONS

56 CONT.

TITLE _____

SHOW BABF19

ACT I

PAGE 30

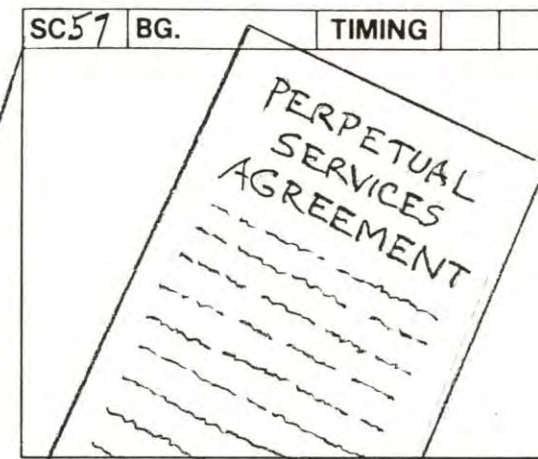
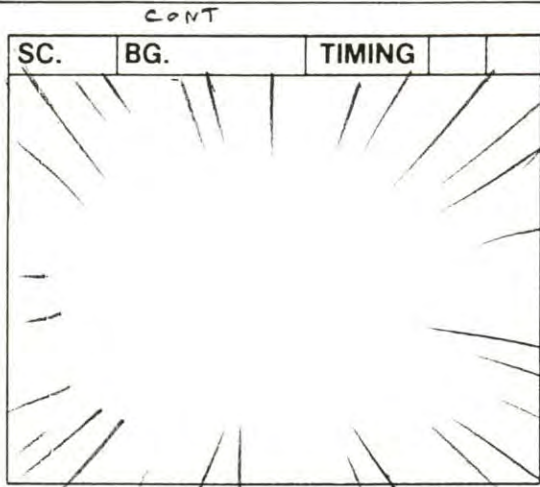
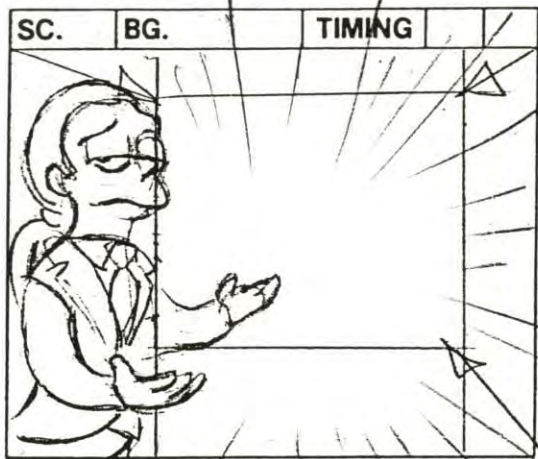

ACTION

TRUCK IN TO ROOM AND TOWARD THE LIGHT.

END POSE OF THE BRIGHT LIGHT.

DISSOLVE TO:

CLOSE-UP on a legal contract. It reads, "Perpetual Services Agreement".

TRANS.

DIAL

NARRATOR (V.O.)

The Simpsons had their foot in the door.

CHORUS: A LA SHOW OPENING / GLISSANDO HARP

DIAGONAL PAN DOWN LONG CONTRACT.

TRANS.

NOTES

FILM ROMAN

THE SIMPSONS

TITLE _____

SHOW BABF19

ACT I

PAGE 31

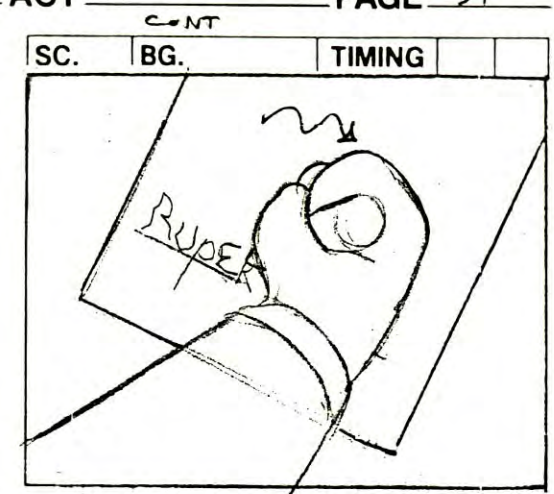
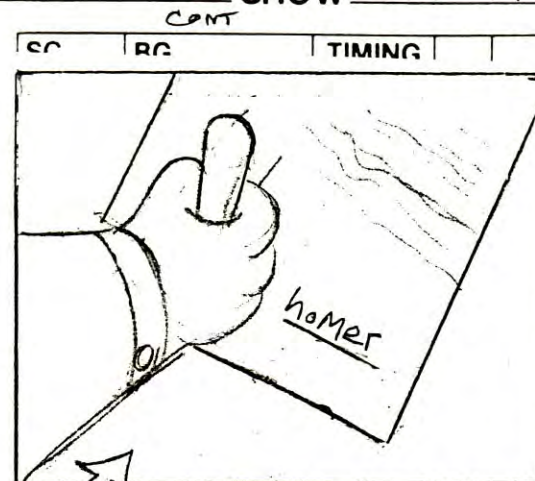
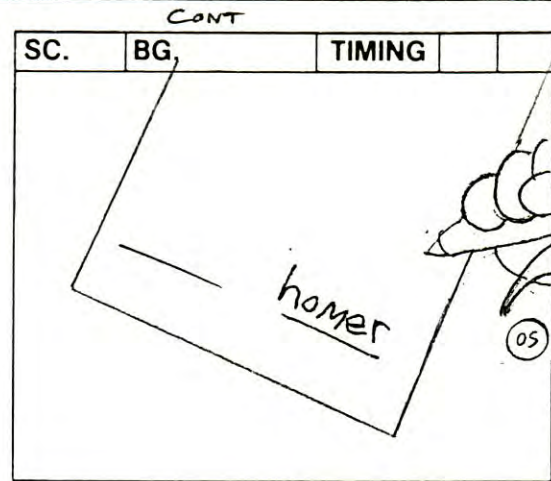
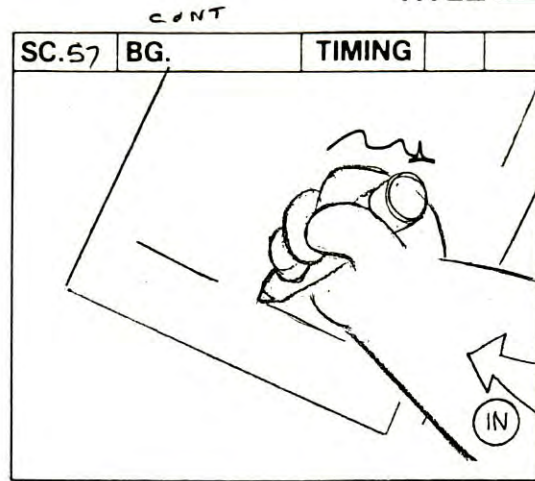

ACTION

Homer's hand enters and signs it with childish block letters.

A different enters from the other side and signs Rupert, also in childish block letters. (Rupert's arm should have an expensive suit sleeve.)

TRANS.

DIAL

NARRATOR (V.O.) (CONT'D)

Fox ordered thirteen episodes. But would the public respond?

TRANS.

NOTES

FILM ROMAN

THE SIMPSONS

TITLE _____

SHOW BABF19

ACT I

PAGE 32

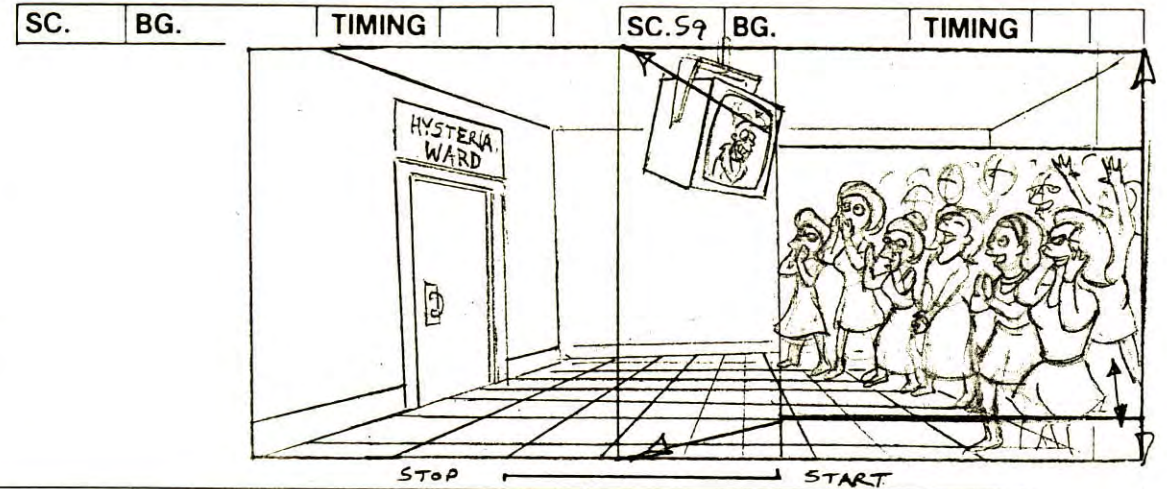
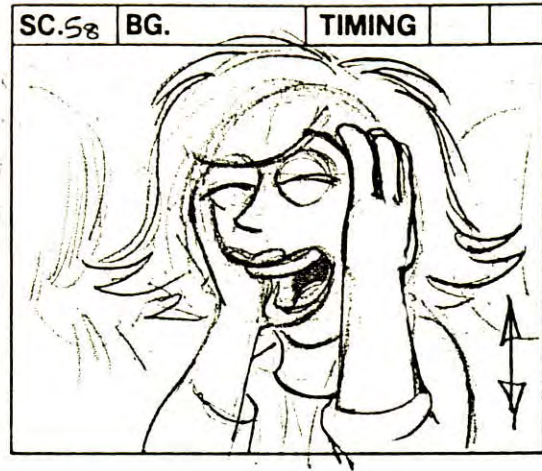
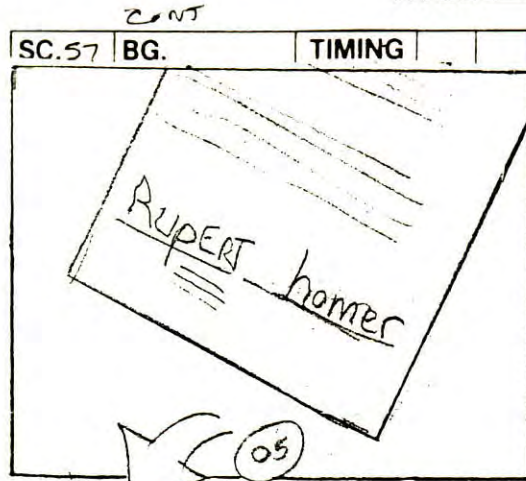

ACTION

C.U. TEENY BOPPER, JUMPING ECSTATICALLY.
(GIRLS IN BG. OUT OF FOCUS)

We start close on a bunch of SCREAMING TEENY BOPPERS à la the Beatles on Ed Sullivan. WIDEN to reveal they're watching the Simpsons on a TV, which is mounted to the ceiling. They SCREAM some more. HOMER ON MONITOR IN SANTA SUIT, SHAKING HEAD,
PAN LEFT TO DOOR.

TRANS.

DIAL

MUSIC: "TWIST AND SHOUT"

TRANS.

NOTES

FILM ROMAN

THE SIMPSONS

TITLE _____ SHOW BADF19 ACT I PAGE 33

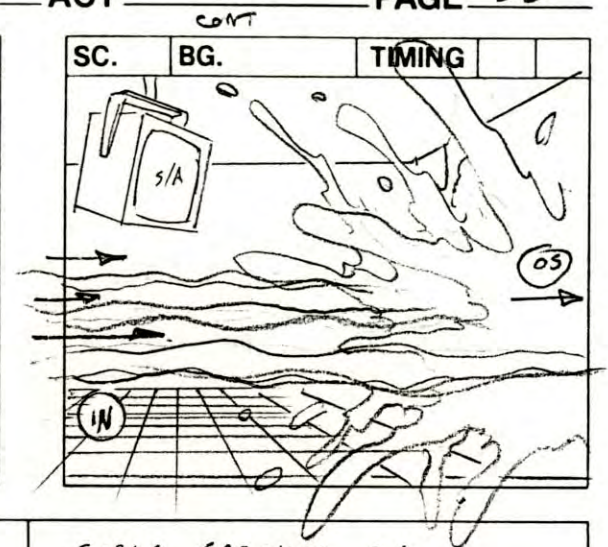
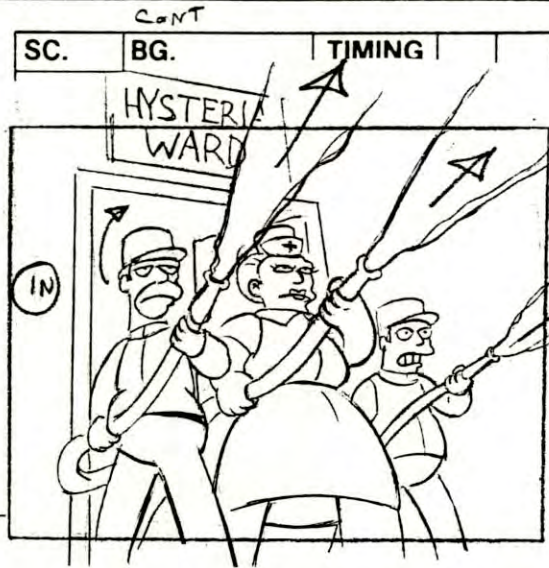
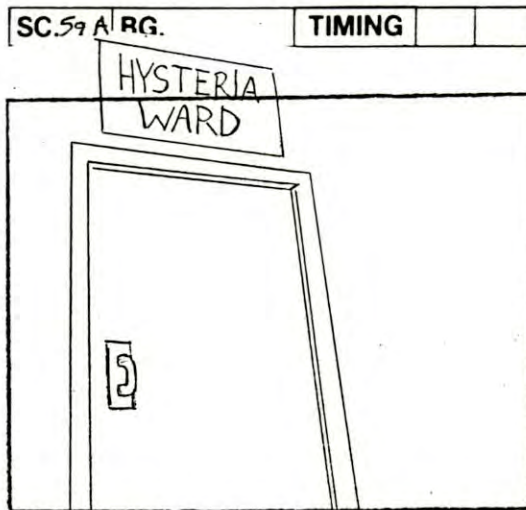

ACTION

UPSHOT HYSTERIA WARD DOOR

A NURSE RATCHET-type character and two ORDERLIES enter through a door which has a sign that reads "HYSTERIA WARD". They are each carrying a high-pressure hose, which they TURN ON

BACK TO SCREAMING GIRLS.

GIRLS SPRAYED O.S.
CAMERA RIGHT.

TRANS.

DIAL

TRANS.

NOTES

FILM ROMAN

THE SIMPSONS

TITLE _____ SHOW BABF19 ACT I PAGE 34

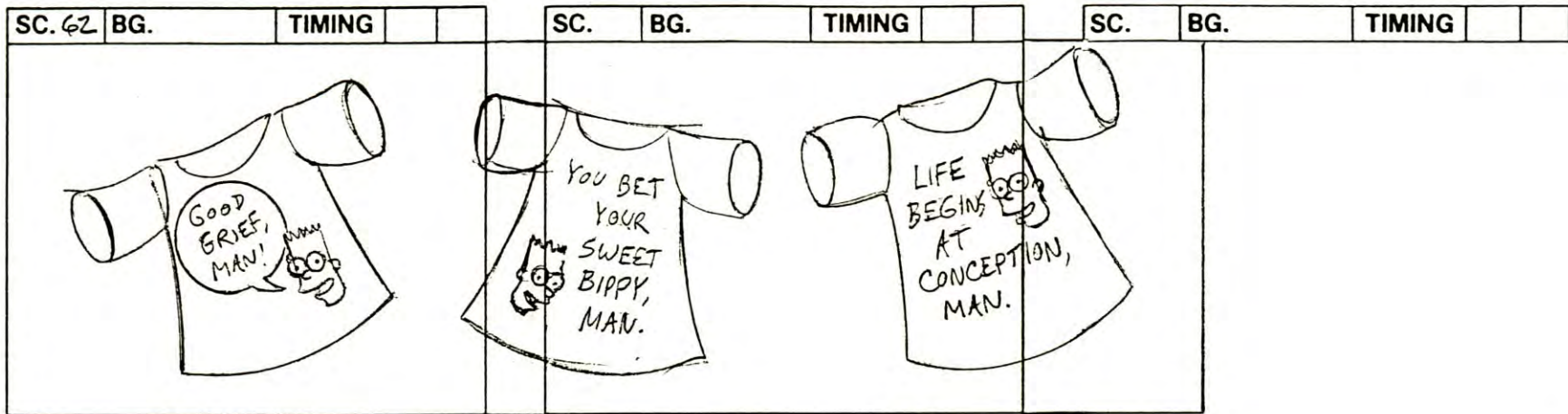
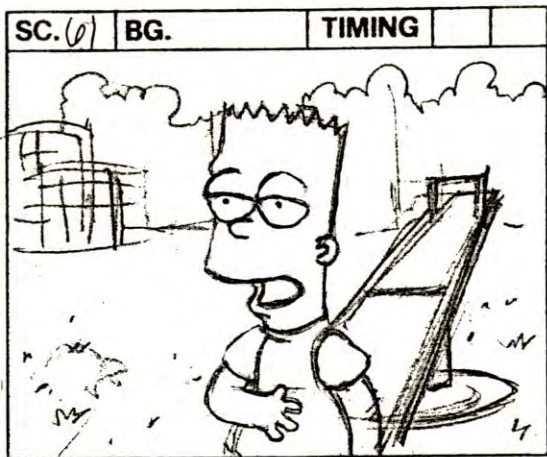

START ← → STOP

ACTION	<p>EXT. PLAYGROUND - DAY.</p> <p>BART INTERVIEW</p> <p>Bart is now sitting on a see-saw.</p>	<p>PAN ACROSS a display of Bart T-shirts reading, "Good Grief, Man"; "You Bet Your Sweet Bippy, Man"; "Life Begins At Conception, Man".</p>
TRANS.		
DIAL	<p>BART</p> <p>I first knew the show was a hit when I walked into school, and a kid was wearing a Bart Simpson T-shirt.</p>	<p>BART (V.O.)</p> <p>Fox had an endless supply of clever slogans, man.</p>
TRANS.		
NOTES		

FILM ROMAN

THE SIMPSONS

TITLE _____

SHOW BABF19

ACT I

PAGE 35

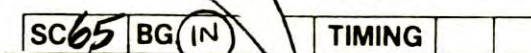
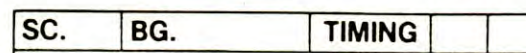
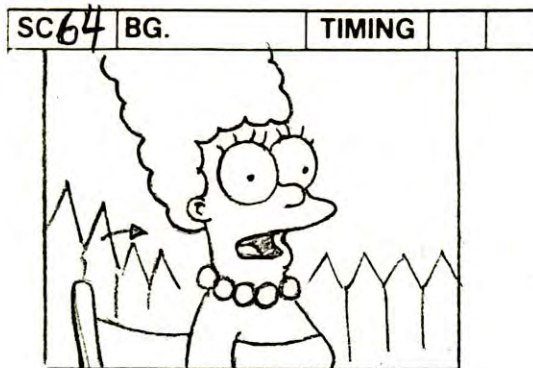
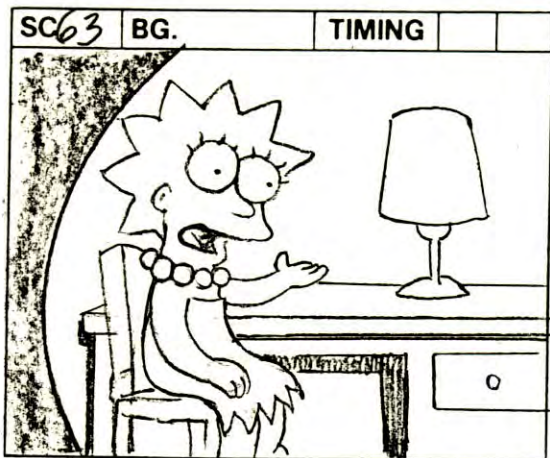

ACTION

INT. LISA'S ROOM.
LISA INTERVIEW

EXT. BACK YARD-DAY.
MARGE INTERVIEW

We see a "Variety" cover (with a picture of the Simpsons looking triumphant) that says, "Yellow Fever!"

TRANS

TRANS

TRANS

DIAL

LISA

People who never said "hi" to me were suddenly asking me to parties. Sherry, Milhouse -- all the glitterati.

MARGE

Once those ratings came in, we had the world by the balls (BLEEP).

NARRATOR (V.O.)

"The Simpsons" was a smash. Viewers couldn't get enough of the show's fractured take on the modern family.

TRANS

TRANS

TRANS

NOTES

NOTES

NOTES

FILM ROMAN

THE SIMPSONS

TITLE _____

SHOW BABF19

ACT I

PAGE 36

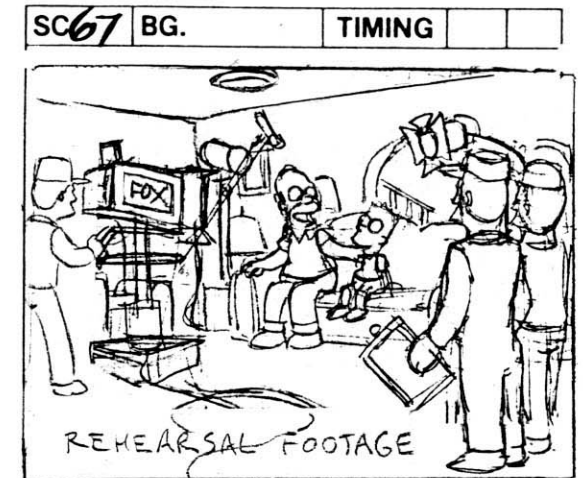
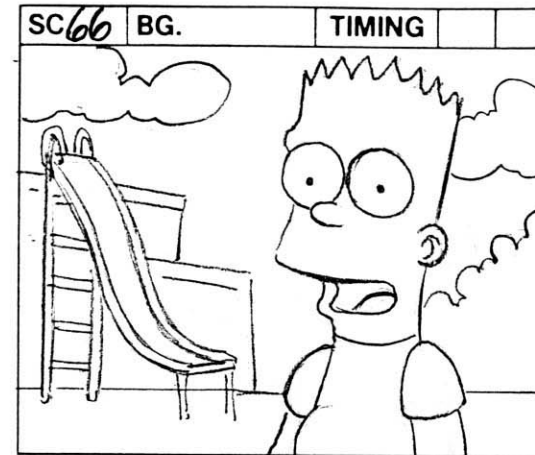
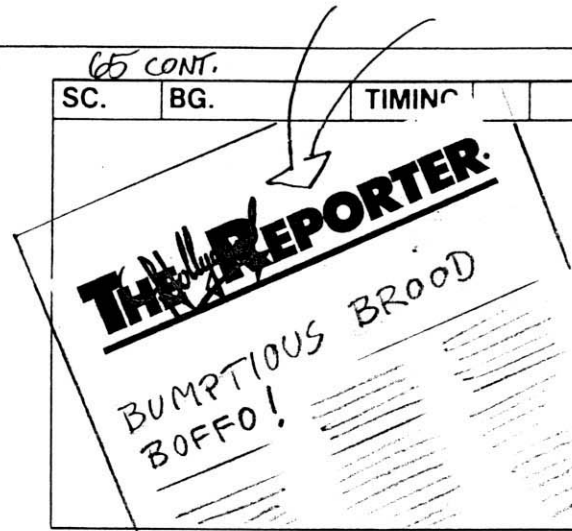

ACTION	<p>NOTE: THIS IS ACTUALLY → "VARIETY" TERMINOLOGY.</p>	<p>Next is a "Hollywood Reporter", which reads, "Bumptious Brood Boffo!"</p> <p>EFX: SHADOW IN OVER "VARIETY"</p>	<p>EXT. PLAYGROUND - DAY.</p> <p>BART INTERVIEW</p>	<p>CUT TO VIDEOTAPE of the Simpson living room, which now has cameras (labeled "Fox") and lighting equipment. Several CREW MEMBERS look on as Homer and Bart rehearse a scene.</p> <p>SUPER: "Rehearsal Footage".</p>
TRANS.				
DIAL			<p>BART</p> <p>The funniest stuff came right out of real life.</p>	<p>HOMER</p> <p>Son, let's go out for frosty chocolate milkshakes.</p>
TRANS.				
NOTES				

FILM ROMAN

THE SIMPSONS

67 CONT.

TITLE _____

SHOW BABF19
PAN SET-UP

ACT I
CONT

PAGE 37

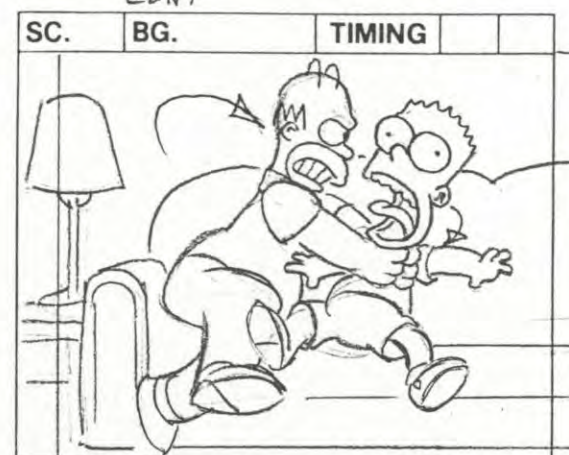
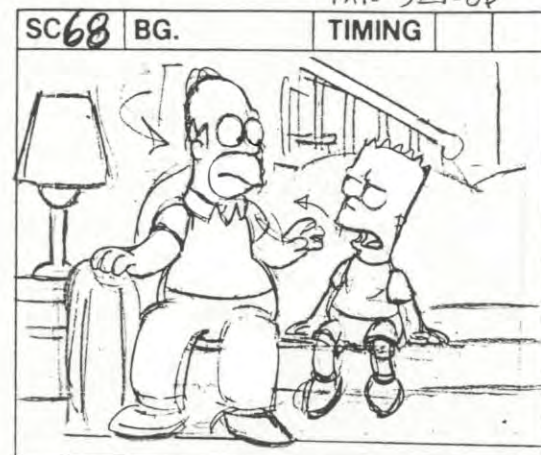
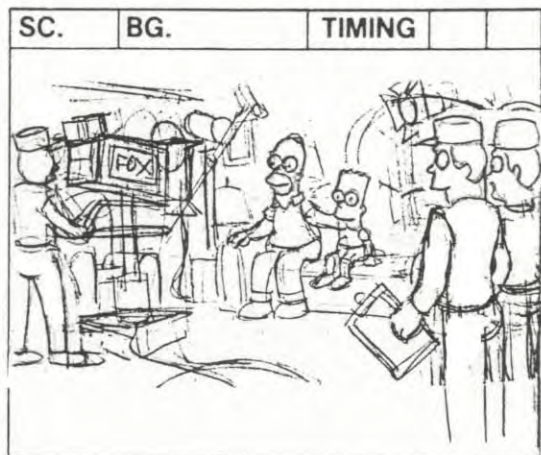
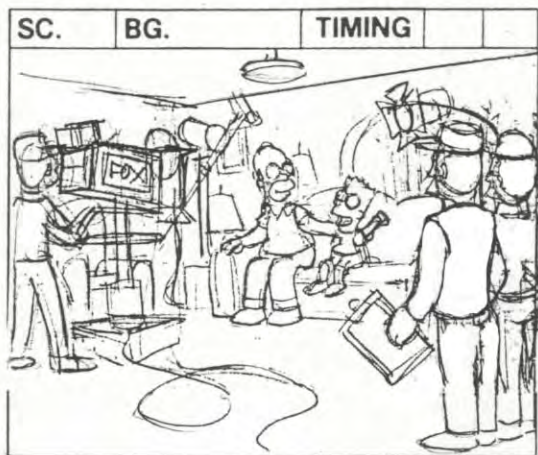

ACTION

BART RAISES FIST IN A "RIGHT ON" GESTURE.

HOMER, BART AND TWO STAGE HANDS TURN TO O.S. DIRECTOR.

CLOSER ON COUCH. HOOK UP HOMER LIFTING HAND FROM BART'S SHOULDER.

START — STOP

ADJUST RIGHT WITH HOMER AS

He STRANGLES Bart.

TRANS.

DIAL

BART
Cowabunga, dude!

DIRECTOR (O.S.)
Aaaand cut!

BART
(DISGRUNTLED) Dad, I've never said "Cowabunga!" in my life. Your script sucks.

HOMER
Why you little...!

TRANS.

NOTES

FILM ROMAN

THE SIMPSONS

TITLE _____

SHOW BABF19

ACT I

PAGE 38

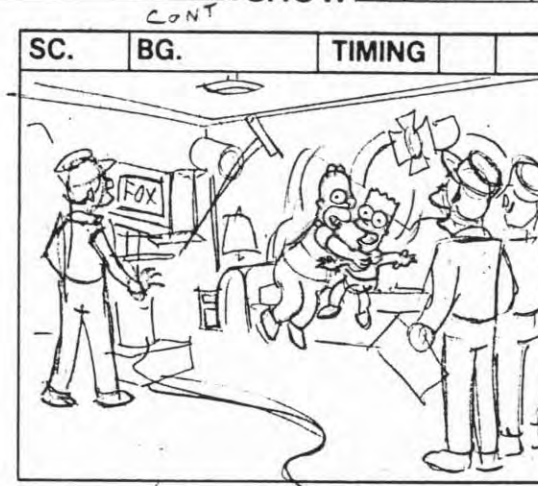
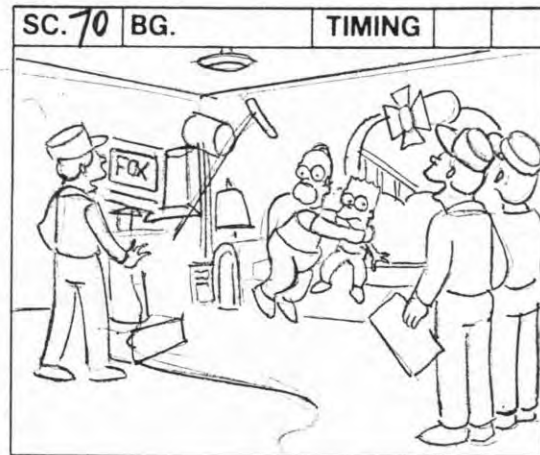

ACTION

ANGLE ON STAGEHANDS
LAUGHING. CREW MEMBER
AT RIGHT SPEAKS.

BACK TO SHOT.

The crew members all
LAUGH at the strangling "shtick."
Homer and Bart react,



then continue the **STRANGLING**, hamming
it up shamelessly.

INT. STAGE. CU HOMER

HOMER INTERVIEW

TRANS.

DIAL

CREW MEMBER
Hey, that's funny!

HOMER

And that horrible act of child abuse
became one of our most beloved running
gags.

TRANS.

NOTES

FILM ROMAN

THE SIMPSONS

TITLE _____

SHOW BABF19

ACT I

PAGE 39

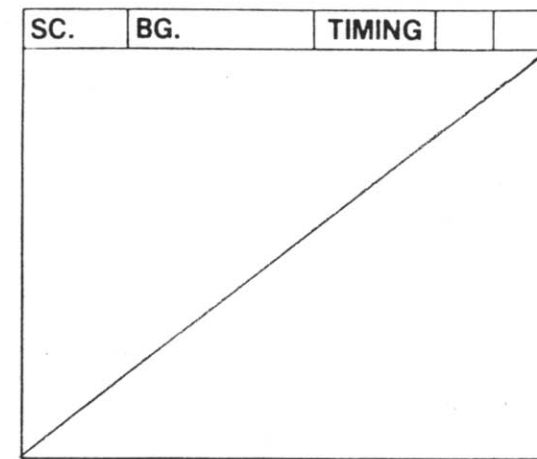
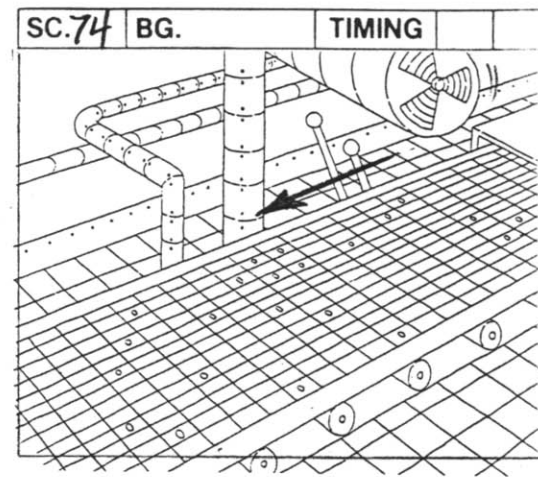
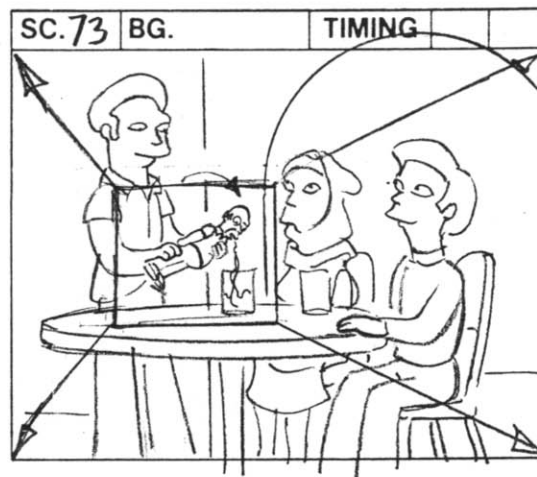
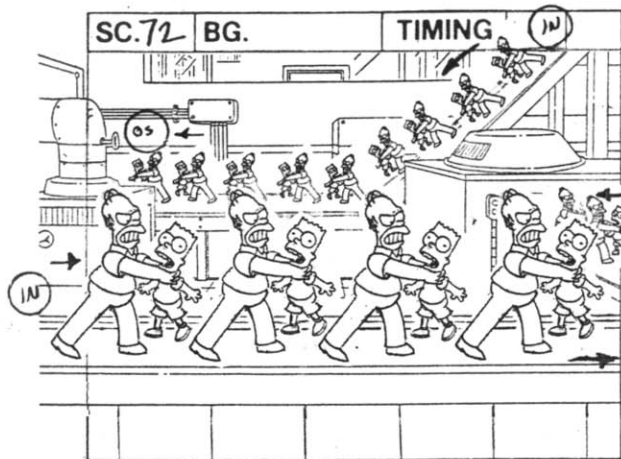

ACTION	<p>INT. TOY SHOP</p> <p>CUT TO NEWS FOOTAGE of Simpson dolls rolling off an assembly line.</p>	<p>EXT. INDONESIAN PLAZA-DAY.</p> <p>We see an INDONESIAN MAN proudly serving liquor to his friends from a Homer-shaped decanter.</p>	<p>INT. US. MINT.</p> <p>STOCK FOOTAGE: Big sheets of currency roll off a printing press.</p>	
TRANS.				
DIAL	<p>NARRATOR (V.O.)</p> <p>With Simpson merchandise selling like crazy...</p>	<p>NARRATOR (V.O.)</p> <p>And Simpson gin wetting whistles worldwide...</p>	<p>NARRATOR (V.O.)</p> <p>The money was pouring in.</p>	
TRANS.				
NOTES				

FILM ROMAN

THE SIMPSONS

TITLE _____ SHOW BABF19 ACT I PAGE 40

SC. 76 IS OUT

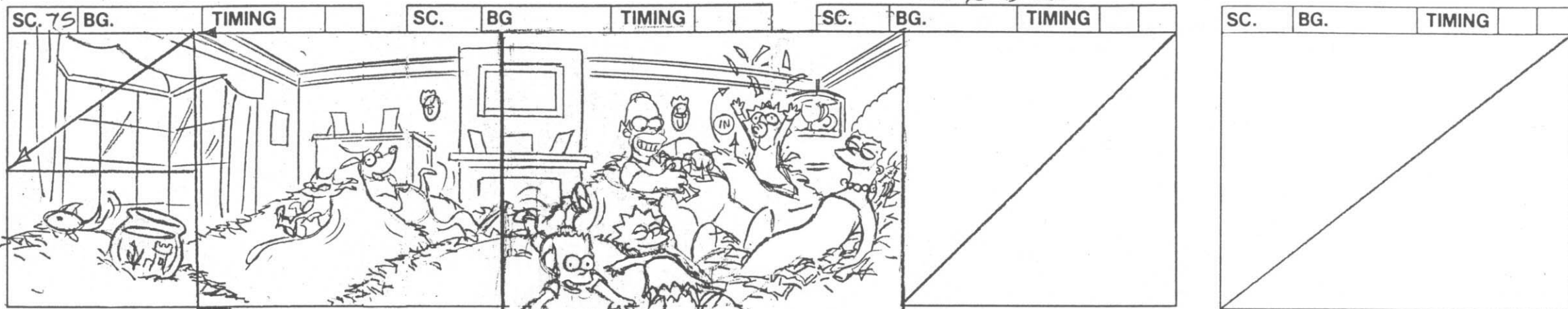

ACTION

STOP + | START 2

STOP |

START 1

We see a shot of the Simpsons lying on a pile of money which fills the background. They ROLL around HAPPILY. PAN OVER to Santa's Little Helper and Snowball II also ROLLING around happily in the money. PAN OVER a little further to the Simpsons' GOLDFISH FLOPPING around happily (not in its bowl) in the money.

* LAYOUT: PLEASE
KEEP SIZE COMP.

TRANS.

DIAL

TRANS.

NOTES

FILM ROMAN

THE SIMPSONS

SC. 76 IS OUT

TITLE _____

SHOW BABF19

ACT 2

PAGE 41

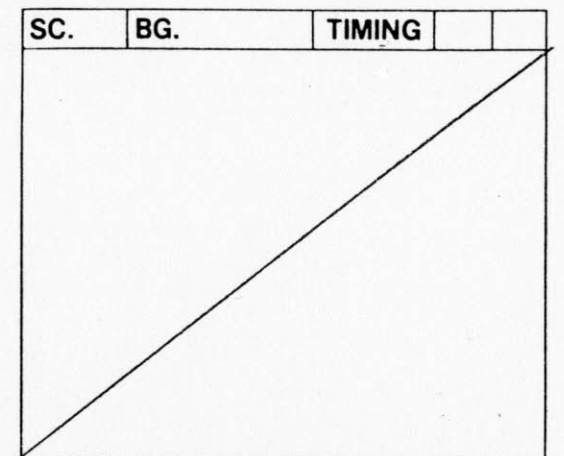
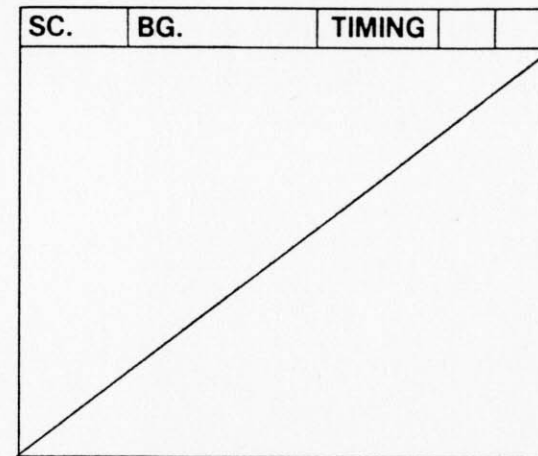
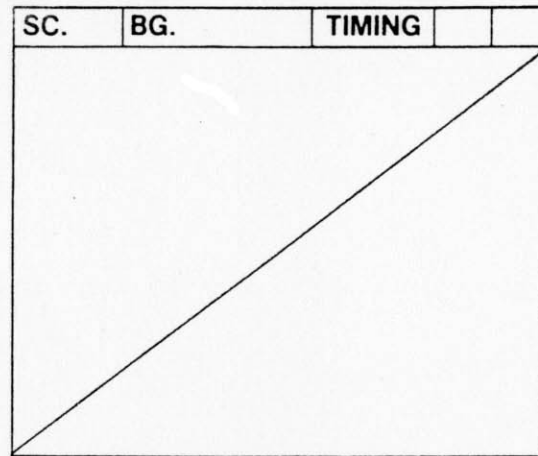
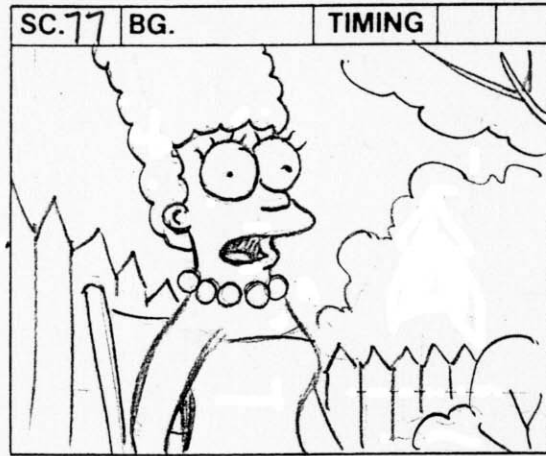

ACTION EXT. BACK YARD - DAY.

MARGE INTERVIEW

TRANS.

DIAL

MARGE

We were using fifty-dollar bills as toilet paper. And toilet paper as dog toilet paper.

TRANS.

NOTES

TITLE _____

SHOW BABF19

ACT I

PAGE 42

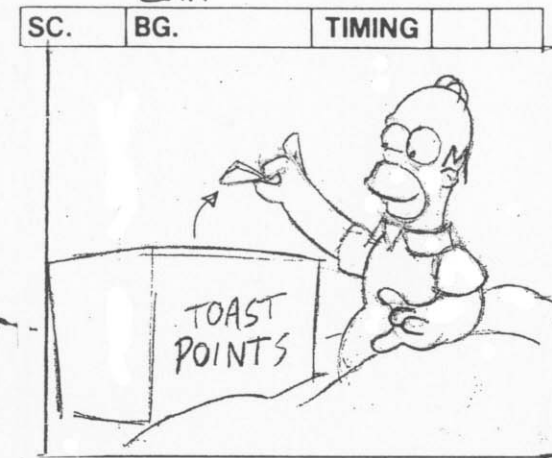
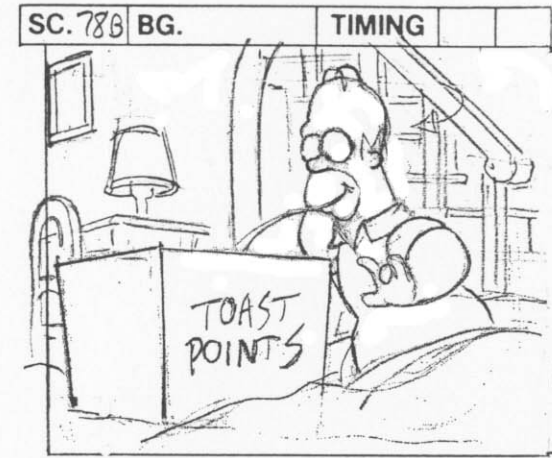
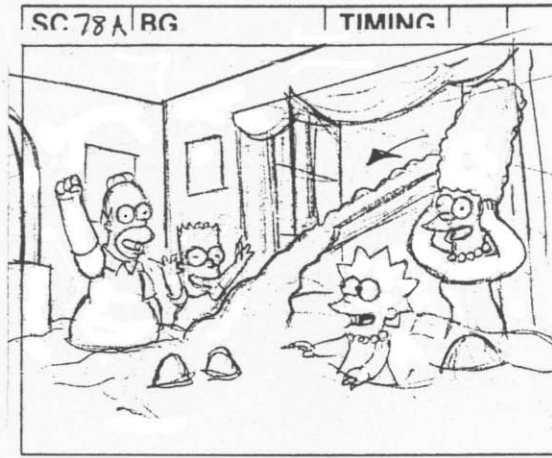
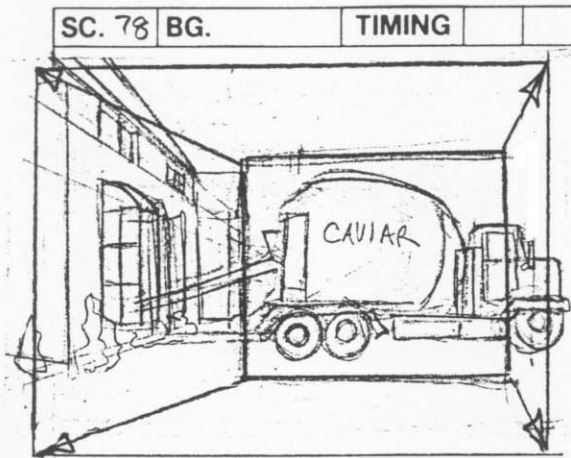

ACTION

A CLOSE UP of a cement mixer. On the side it reads "Caviar". WIDEN to reveal the truck's metal chute is POURING caviar into the Simpsons' house through an open window.

Homer reaches into a huge crate clearly labeled "TOAST POINTS", pulls out one toast point,

TRANS.

INT. SIMPSON HOUSE - LIVING ROOM - CONTINUOUS

The GIDDY Simpsons sit on the floor as the caviar GUSHES in around them.

DIAL

TRANS.

NOTES

FILM ROMAN

THE SIMPSONS

PAGE 42B IS NEXT.

TITLE _____

SHOW BABF19

ACT I

PAGE 42A

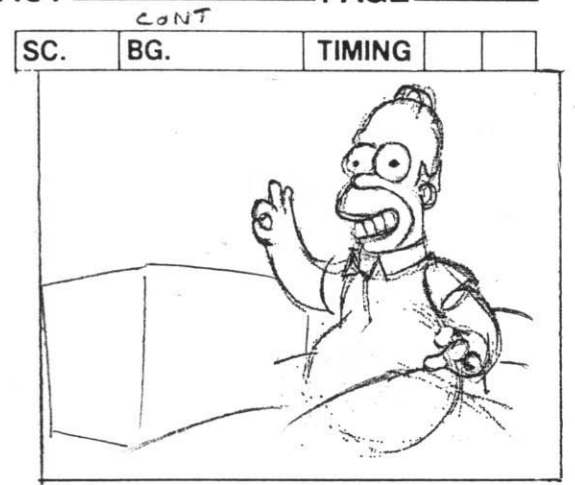
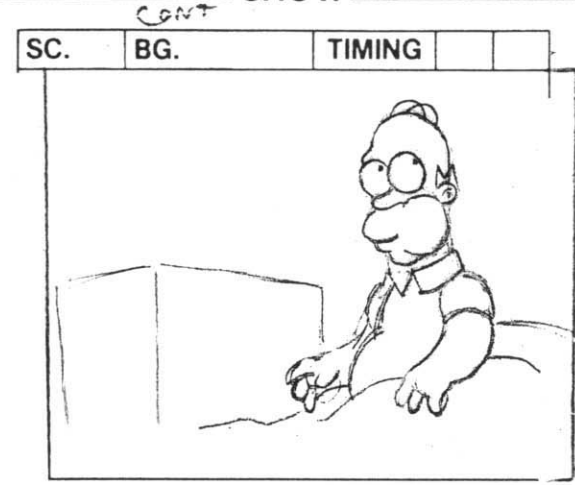
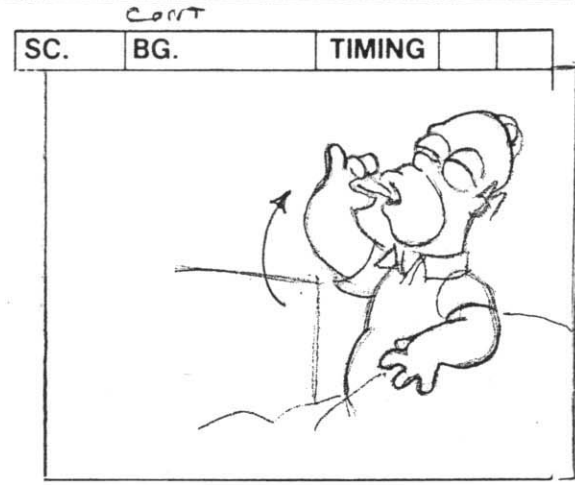
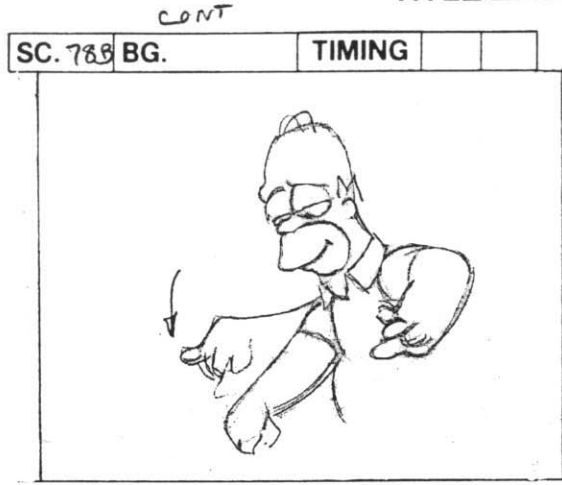

ACTION

He daintily
dips it into the caviar

and eats it.

He nods, satisfied

TRANS.

DIAL

TRANS.

NOTES

FILM ROMAN

THE SIMPSONS

PAGE 43 IS NEXT

TITLE _____

SHOW BABF19

ACT I

PAGE 42B

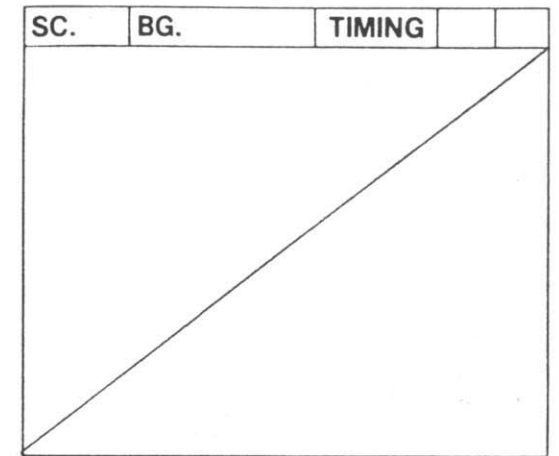
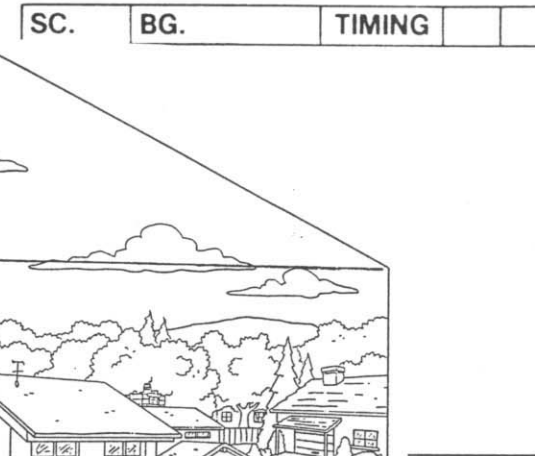
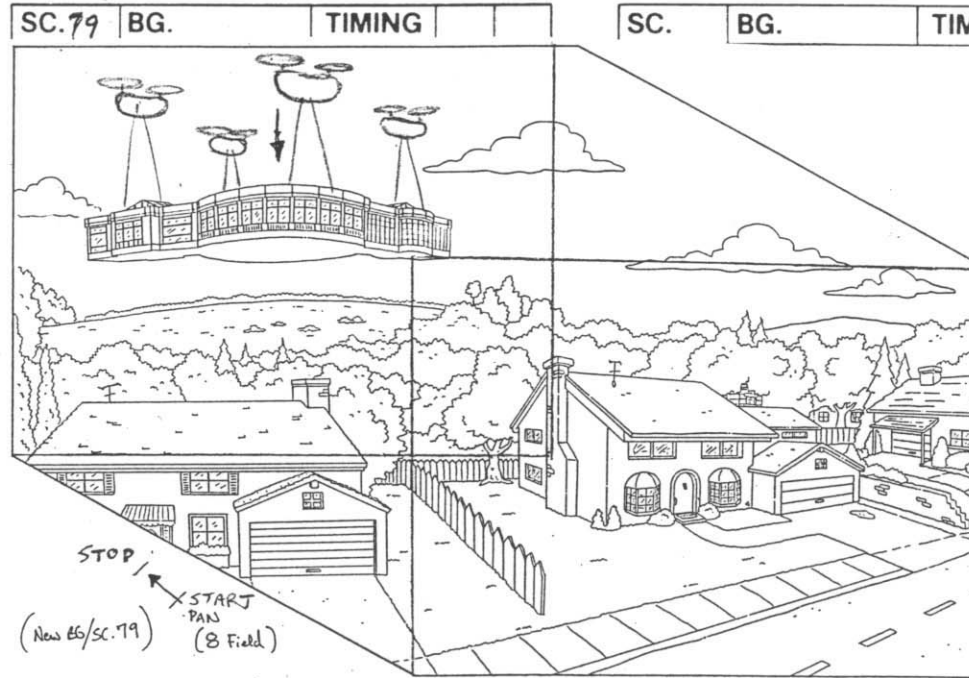
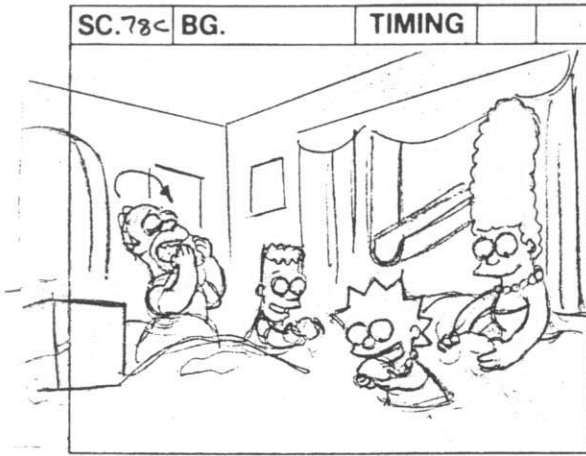

ACTION

and they all start scooping up the caviar with their hands and shoving it in their mouths.

TRANS.

We see the Simpsons' house (without the trucks and other accoutrements of TV production). WIDEN to reveal a huge mansion being lowered into place behind it.

DIAL

NARRATOR (V.O.)

Convinced that the good times would never stop rolling, the Simpsons moved out of their trademark house...

TRANS.

NOTES

FILM ROMAN

THE SIMPSONS

TITLE _____

SHOW BABF19

ACT I
CONT

PAGE 43

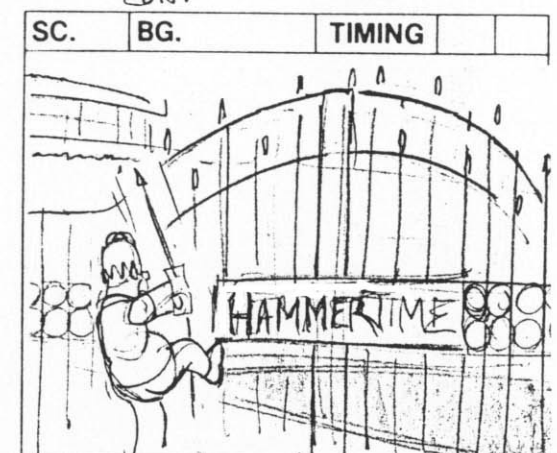
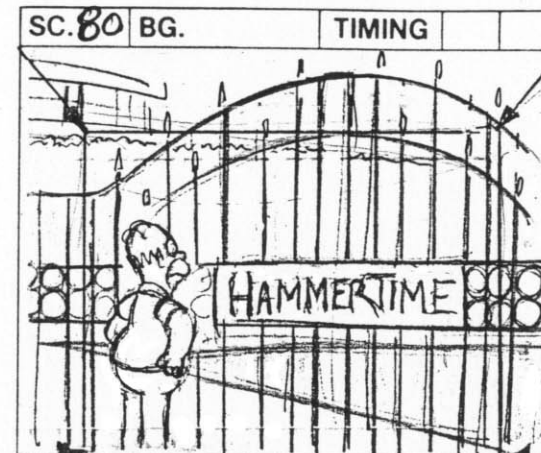
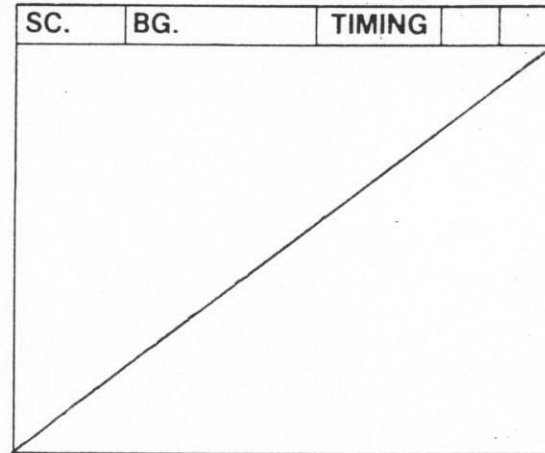
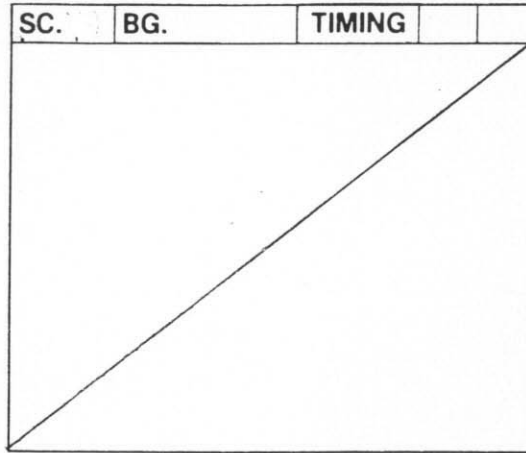

ACTION

TRUCK IN.

We CUT TO Homer, standing by a gate reading, "Hammer Time". Homer pulls an iron hammer off of the gate,

TRANS.

DIAL

NARRATOR (V.O.) (CONT'D)

...and into MC Hammer's.

TRANS.

NOTES

FILM ROMAN

THE SIMPSONS

80 CONT.

TITLE _____

SHOW BABF19
SC. 81 IS OUT

ACT I

PAGE 44
SMALL FIELD

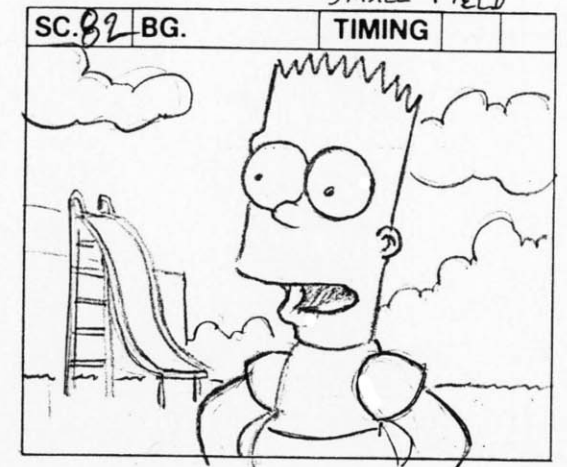
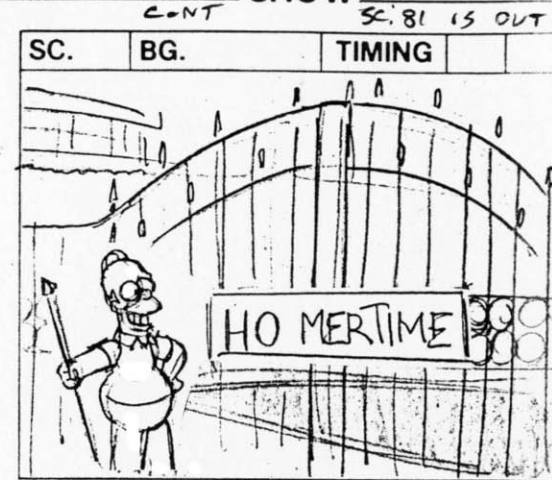
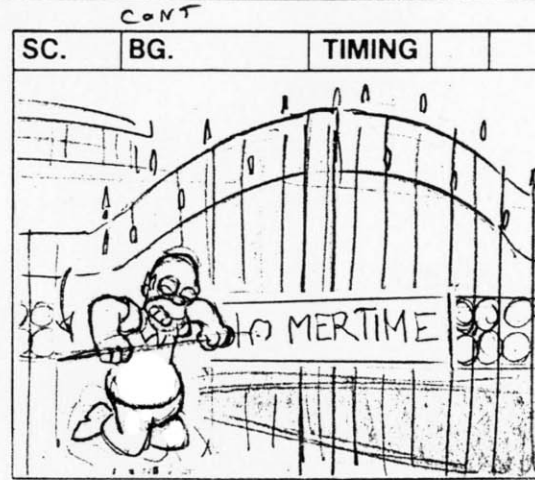
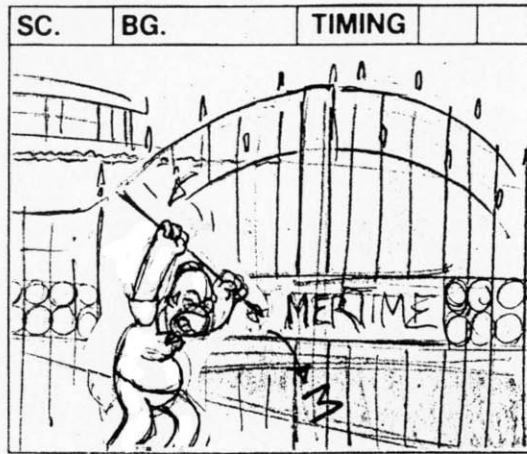

ACTION

and knocks off one of the "m"'s.

(* play fast)

He bends the "a" into an "o",

so it reads, "Homer Time".

EXT. PLAYGROUND - DAY.

BART INTERVIEW

TRANS.

DIAL

BART

We found a secret room that was filled to the ceiling with parachute pants.

TRANS.

NOTES

FILM ROMAN

THE SIMPSONS

SHOW BABF19

ACT I

PAGE 45

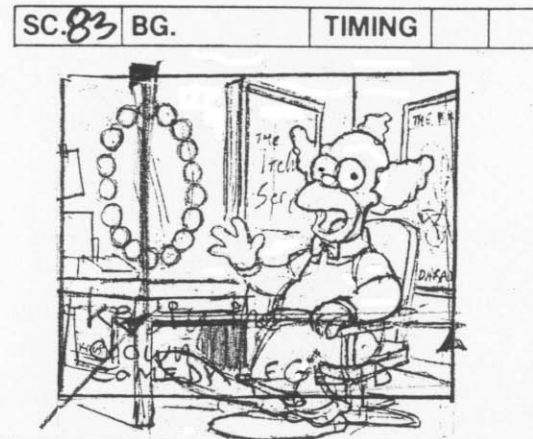
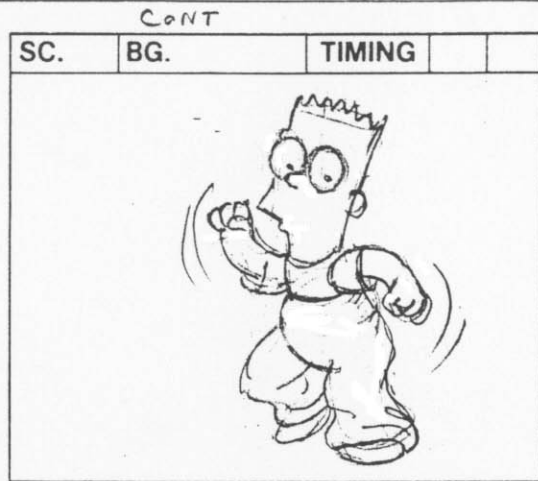
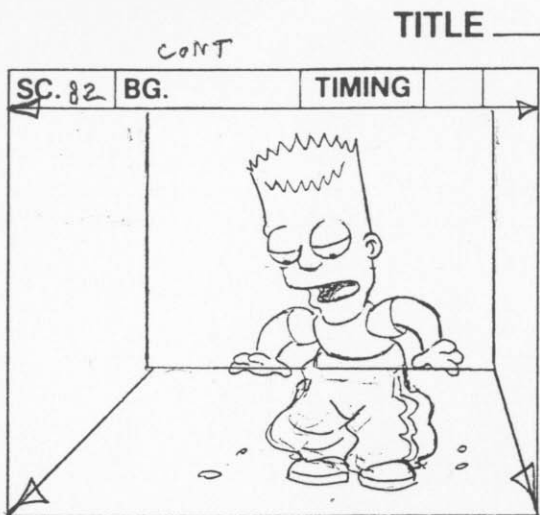

ACTION

CAMERA TRUCKS OUT TO REVEAL
a spangly pair of
billowing pants.

Bart does a quick Hammer-style dance
move.

KRUSTY INTERVIEW

He's sitting at his make-up mirror.
SUPER: "KRUSTY THE CLOWN -- Comedy
Legend".

KRUST GRABS LP RECORD.

TRANS.

BART (CONT)
I'm wearing some now.

Truck - in.



DIAL

MUSIC: "CAN'T TOUCH THIS"

NARRATOR (V.O.)

But pants or no pants, the Simpsons
were flying high.

KRUSTY

Yeah, I've seen all the overnight
sensations -- Brad Hall, Rich Hall,
Rich Little, Little Richard -- but the
Simpsons blew 'em all away. They even
had a hit record.

(BITTERLY)

Meanwhile, "Krustophenia" sits on the
shelf.

TRANS.

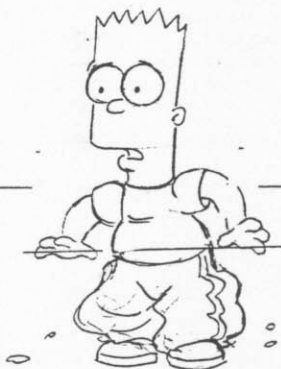

NOTES

FILM ROMAN

THE SIMPSONS

TITLE _____ SHOW BABF19 ACT I PAGE 46

SC.	BG.	TIMING
-----	-----	--------

SMALL FIELD

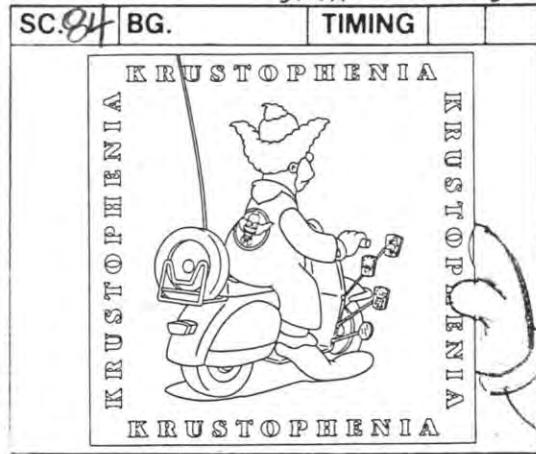

CONT

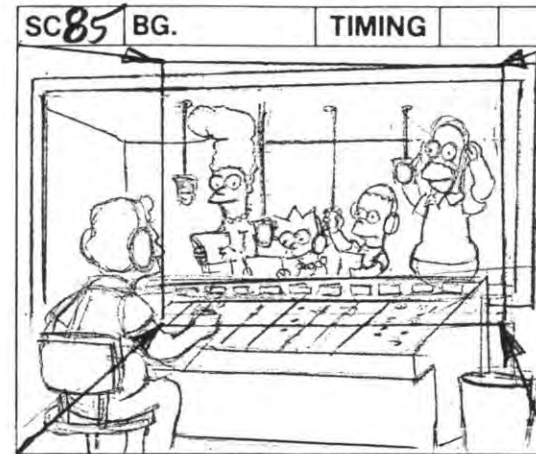
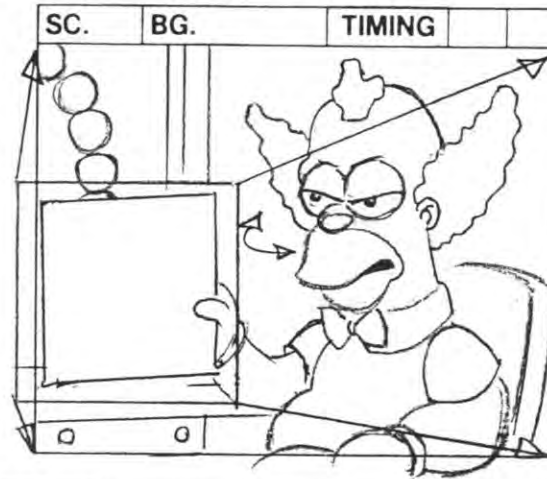

ACTION

He holds up the album.

The cover is just like The Who's "Quadrophenia," only with Krusty.

Design by Kevin Moore

TRUCK OUT.

He shakes his head in frustration for a long beat.

DISSOLVE TO PUBLICITY FOOTAGE of the Simpsons in a recording studio. They put on headsets and adjust their microphones.

TRUCK IN TO FAMILY.

TRANS.

DIAL

TRANS.

NOTES

FILM ROMAN

THE SIMPSONS

TITLE _____

SHOW BABF 19

ACT I
CONT

PAGE 47

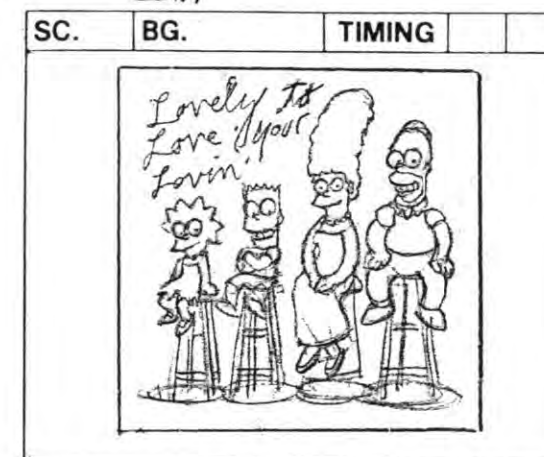
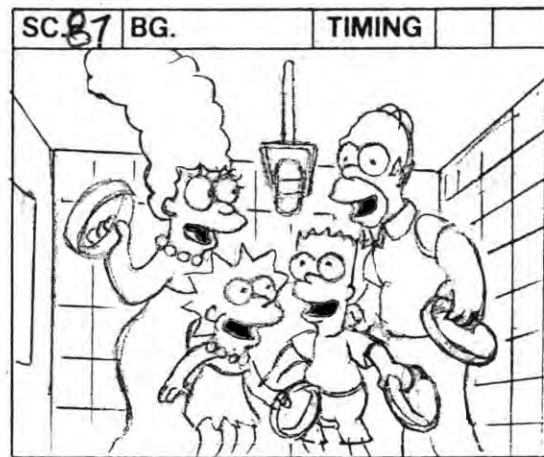
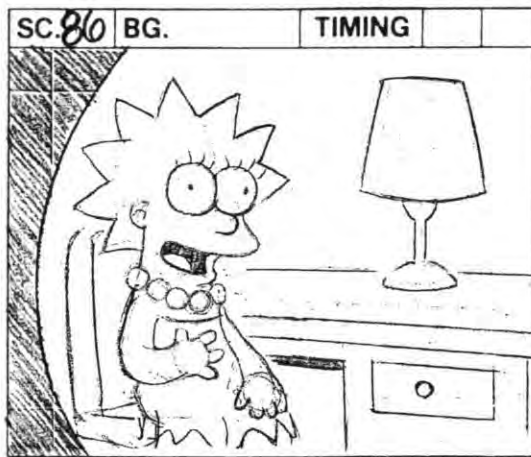

ACTION

INT. LISA'S ROOM.

LISA INTERVIEW

INT. RECORDING STUDIO.

CUT TO the Simpsons recording a generic pop song. They are all playing tambourines and singing.

* Albums in stylized sequence, with Albums moving in from sides, displacing the previous one.
We see record jackets sail past for the following titles:

TRANS.

DIAL

LISA

None of us had ever sung before. But Mr. Geffen believed in us.

SIMPSONS

(SINGING) WE'RE GONNA GROOVE TONIGHT / WE'LL MAKE YOU FEEL ALL RIGHT / SIMPSONS BOOGIE!

NARRATOR (V.O.)

"Simpsons Boogie",

"Lovely to Love Your Lovin'",

TRANS.

NOTES

FILM ROMAN

THE SIMPSONS

88 CONT.

TITLE _____

SHOW BABF19

ACT I

PAGE 48

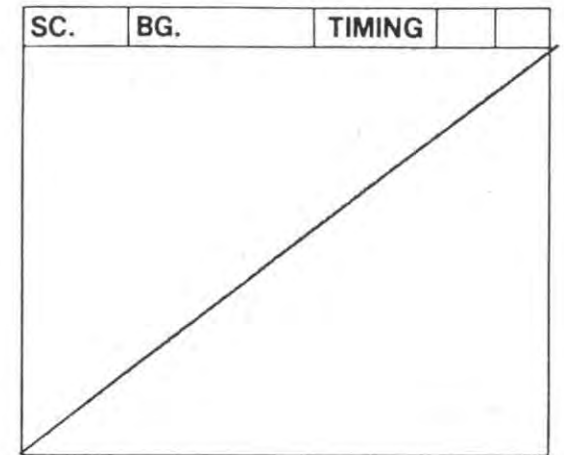
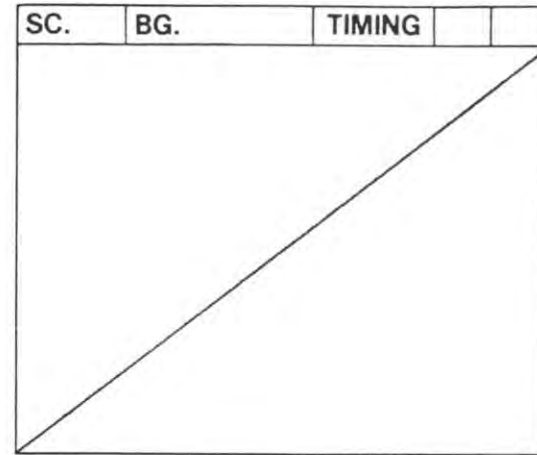
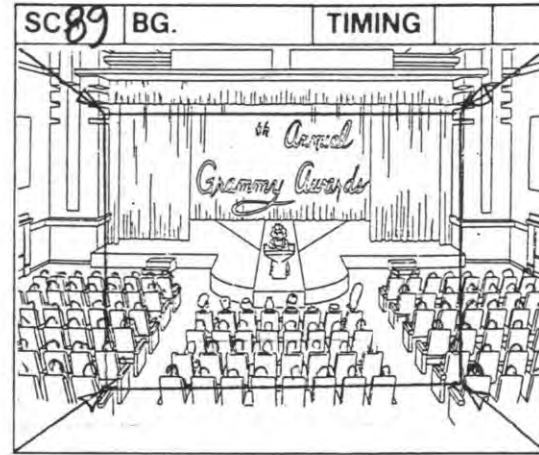
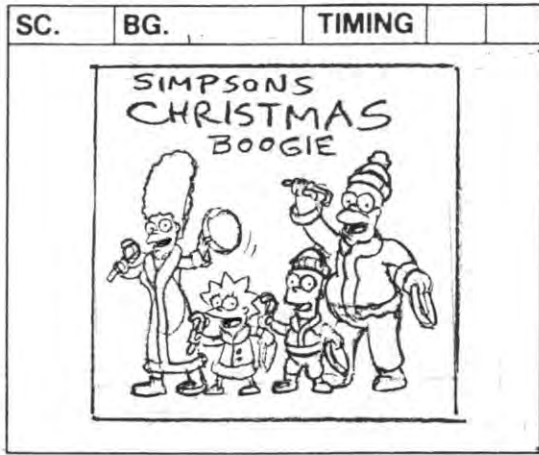

ACTION		<p>WIDE ANGLE - TRUCK IN</p> <p>GRAMMY FOOTAGE --</p>		
TRANS.				
DIAL	<p>and "Simpsons' Christmas Boogie" went mega-platinum and swept the Grammys.</p>	<p>OSZV OSBOURNE</p> <p>Right,</p>		
TRANS.				
NOTES				

FILM ROMAN

THE SIMPSONS

TITLE _____

SHOW BABF19

ACT I
CONT

PAGE 49

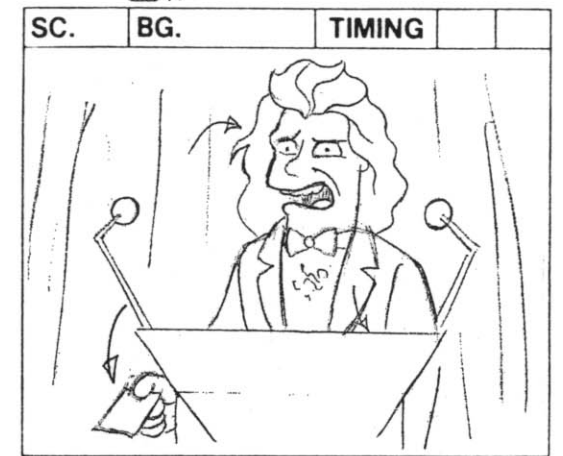
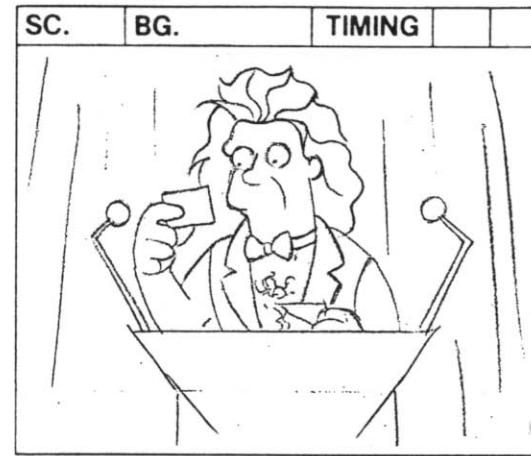
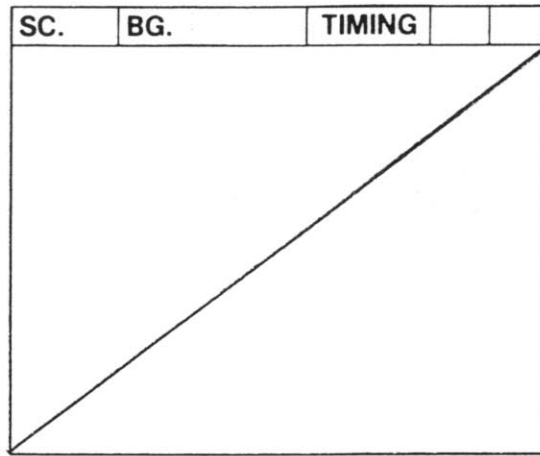

ACTION

OZZY OSBOURNE is at the podium, in a tux jacket and no shirt.
SUPER: "OZZY OSBOURNE".

HE LOOKS SURPRISED.

HE LEANS BACK, DISGUSTED

TRANS.

OZZY OSBOURNE (CONT)
and the award for "Best Hardcore Thrashmetal" goes to...

(DISGUSTED)

"Simpsons' Christmas Boogie"?!

DIAL

TRANS.

NOTES

FILM ROMAN

THE SIMPSONS

TITLE _____ SHOW BABF19 ACT I PAGE 50

SC.9 | BG. | TIMING



SC.92 | BG. | TIMING



CONT SC. | BG. | TIMING



SC.93 | BG. | TIMING

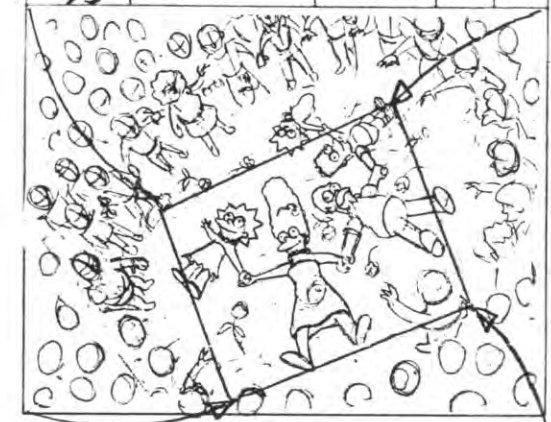

ACTION

The CROWD CHEERS. The Simpsons, already holding armloads of Grammys, jump up excitedly.
EFX: SPOTLIGHT SWEEPS

OZZY ANTICS TO BITE GRAMMY TROPHY.

(the gold megaphone) off of the Grammy. For some reason, blood spurts out.

Ozzy angrily BITES the head

We CUT TO a STYLIZED SHOT of the smiling Simpsons lying in a field of flowers, surrounded by FANS who shower them with roses.

RACKET IN.

TRANS.

CROWD, SHINES ON SIMPSONS.

DIAL

TRANS.

NOTES

NARRATOR (V.O.)

For America's favorite family,

FILM ROMAN

THE SIMPSONS

TITLE _____

SHOW BABF19

ACT I
CONT

PAGE 51

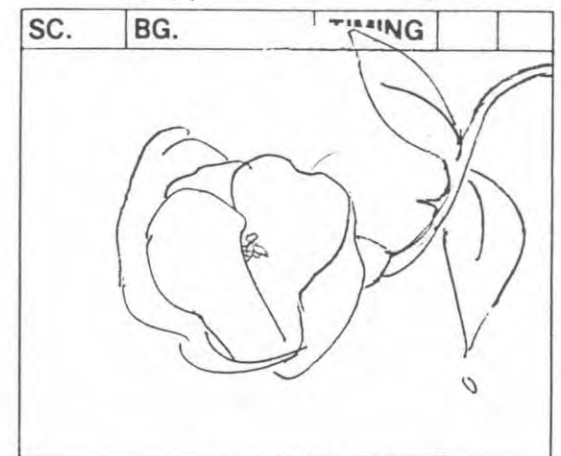
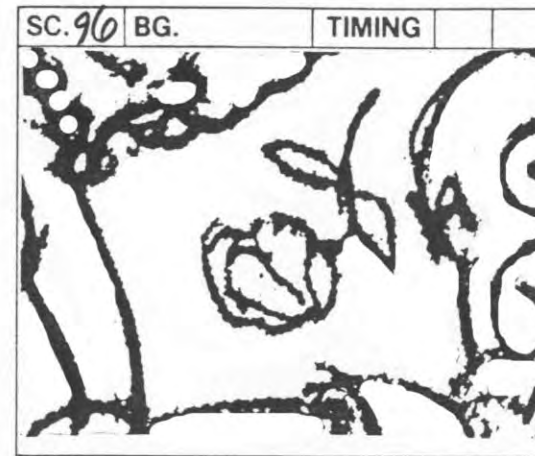
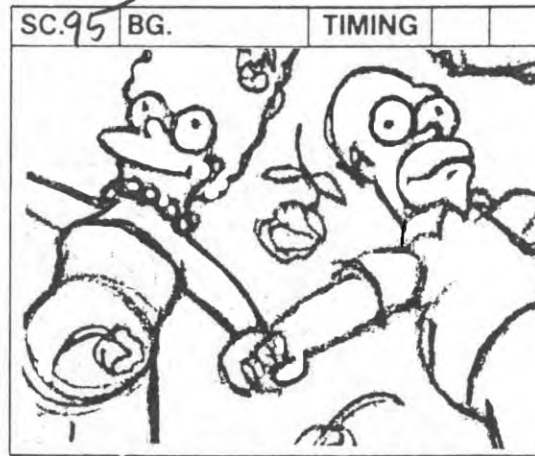
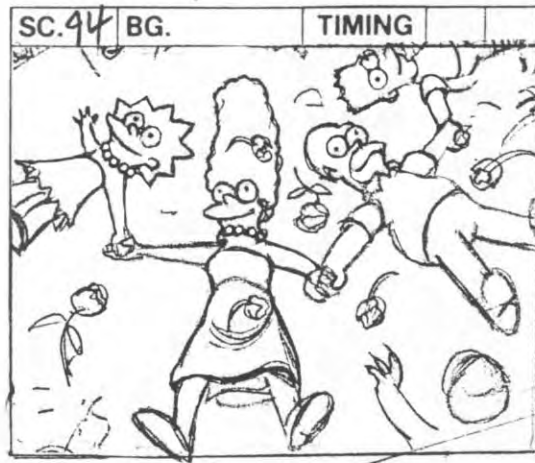

ACTION	CONTINUE RACKET.	RACKET IN on a rose.		BEE in ROSE. CONTINUE RACKET.
TRANS.				
DIAL	everything was coming up roses...	(OMINOUS)	but those roses contained ready-to-sting bees.	
TRANS.				
NOTES				

FILM ROMAN

THE SIMPSONS

TITLE _____ SHOW BABE19 ACT I PAGE 52

SC. 97 BG. TIMING

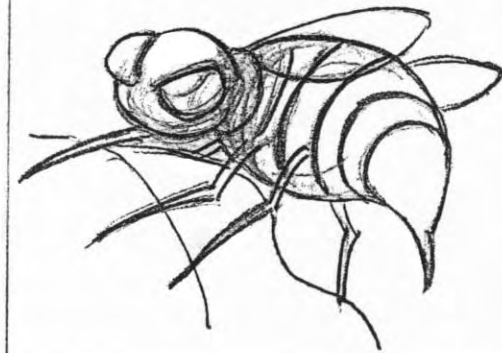

SC. BG. TIMING

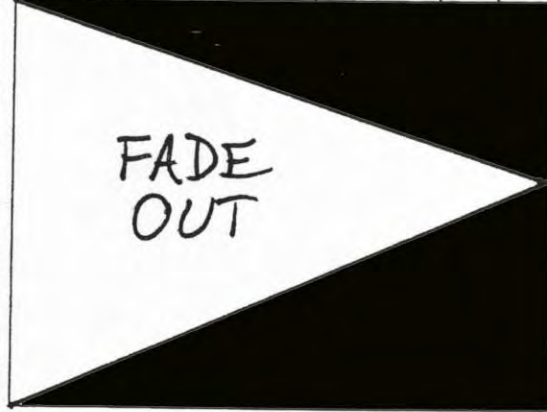

SC. BG. TIMING

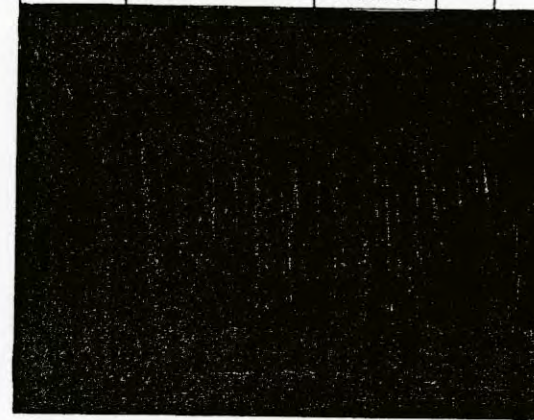

SC. 98 BG. TIMING

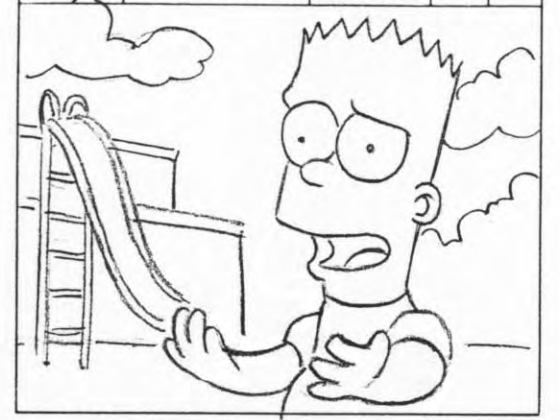

ACTION

<p>Inside we see an ANGRY BEE, his stinger poised.</p>	<p>FADE TO BLACK.</p>		<p>EXT. PLAYGROUND - DAY.</p> <p style="text-align: center;">BART INTERVIEW</p>
--	-----------------------	--	--

TRANS.

DIAL

NARRATOR (V.O.)
When we come back...

BART
I felt something sticky, then I realized it was blood.

TRANS.

NOTES

FILM ROMAN

THE SIMPSONS

TITLE _____

SHOW BABE 19

ACT I

PAGE 53

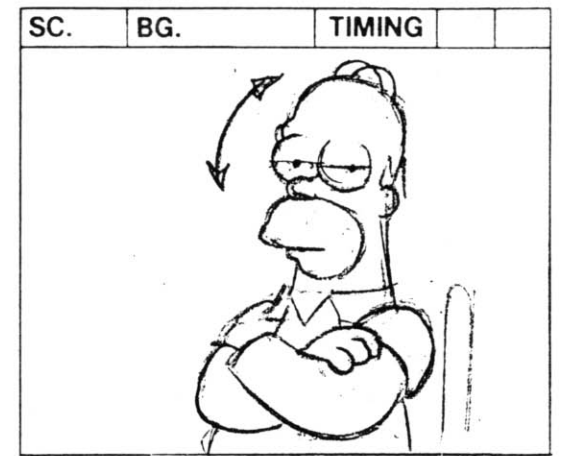
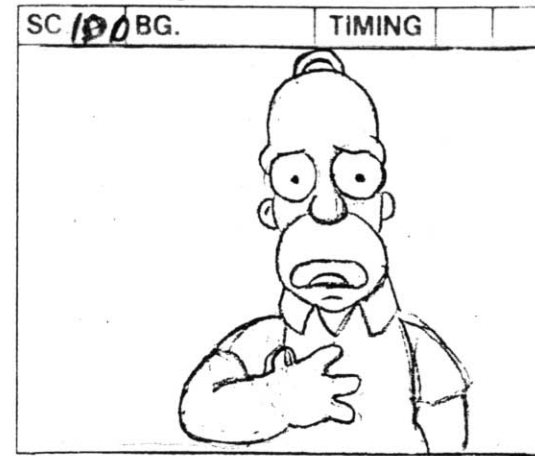
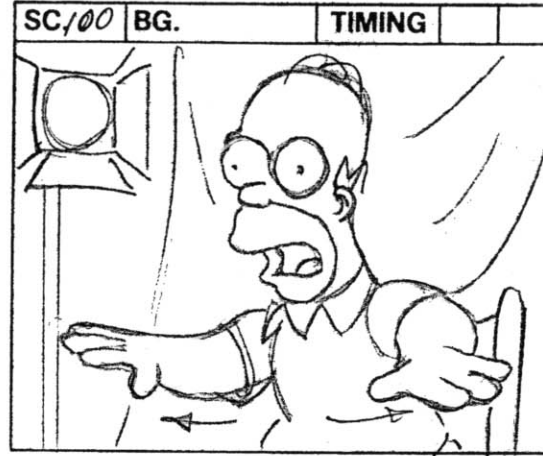
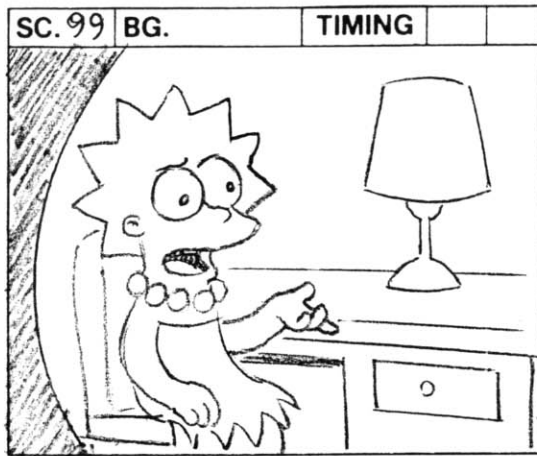

ACTION	INT. LISA'S ROOM. LISA INTERVIEW	INT. STUDIO. HOMER INTERVIEW	HOMER TURNS TO CAMERA. He smugly sits back, arms folded, and nods assuredly.
TRANS.			
DIAL	LISA If I were gonna shoplift, why would I do it at Pep Boys?	HOMER I want to set the record straight.	HOMER (CONT) (DELIBERATELY, TO CAMERA) I thought the cop was a prostitute.
TRANS.			
NOTES			

FILM ROMAN

THE SIMPSONS

Sc. 101 is out TITLE _____ SHOW BABF19 ACT I PAGE 54

SC.	BG.	TIMING		
/				

SC. 102	BG.	TIMING		
BEHIND THE LAUGHTER				

SC.	BG.	TIMING		
FADE OUT				

SC.	BG.	TIMING		
END OF ACT I				

ACTION		Graphics fly in again. FROM CAMERA LEFT. ANIMATE LETTERS	FADE OUT:	<u>END OF ACT ONE</u>
TRANS.				
DIAL		NARRATOR (V.O.) When "Behind the Laughter" continues.		
TRANS.				
NOTES				